

Evaporative Retrofit Components for Roof Top Packaged Air-conditioning Units

ET Project Number: ET12PGE3181



Project Manager: Marshall Hunt
Pacific Gas and Electric Company

Prepared By: Antonio Corradini, Kevin Johnson, Akane Karasawa
AESC, Inc.
5927 Balfour Court, Suite 213
Carlsbad, California 92008
Marshall Hunt
PG&E

Issued: December 21, 2012

© Copyright, 2012, Pacific Gas and Electric Company. All rights reserved.

ACKNOWLEDGEMENTS

Pacific Gas and Electric Company's Emerging Technologies Program is responsible for this project. It was developed as part of Pacific Gas and Electric Company's Emerging Technology – HVAC program under internal project number ET12PGE3181. AESC, Inc. conducted this technology evaluation for Pacific Gas and Electric Company with overall guidance and management from Marshall Hunt. Judith Jennings and Robert Davis of PG&E provided valuable input to the project and review of this report. For more information on this project, contact MBH9@pge.com.

LEGAL NOTICE

This report was prepared for Pacific Gas and Electric Company for use by its employees and agents. Neither Pacific Gas and Electric Company nor any of its employees and agents:

- (1) makes any written or oral warranty, expressed or implied, including, but not limited to those concerning merchantability or fitness for a particular purpose;
- (2) assumes any legal liability or responsibility for the accuracy, completeness, or usefulness of any information, apparatus, product, process, method, or policy contained herein; or
- (3) represents that its use would not infringe any privately owned rights, including, but not limited to, patents, trademarks, or copyrights.

Abbreviations and Acronyms

ASHRAE	American Society of Heating, Refrigeration and Air-conditioning Engineers
Btuh	British thermal units per hour
CFM	Cubic Feet per Minute of airflow
CRAC	Computer Room Air Conditioner
DB	Dry Bulb
DP	Dew Point
EE	Evaporative Effectiveness as percent of web bulb depression
EER	Energy Efficiency Ratio in Btu/w
ERC	Evaporative Retrofit Component
OAS	Outdoor Air Supply
OAT	Outside Air Temperature
OEM	Original Equipment Manufacturer
R ²	Coefficient of determination
RH	Relative Humidity
RTU	Roof Top Packaged Unit (often with gas heat and economizer)
WB	Wet Bulb

Contents

EXECUTIVE SUMMARY	1
INTRODUCTION	2
Background	2
Emerging Technology	3
Assessment Objectives	3
EMERGING TECHNOLOGY PRODUCTS	4
Technology	4
Thermodynamics.....	4
Target Markets	9
Market Barriers	9
Technology/Product Evaluation	10
Technical Approach/Test Methodology.....	11
Test Plan.....	11
Baseline Monitoring	12
Post Installation Monitoring	12
Instrumentation Plan	15
Analysis Methodology	16
Results	20
ERC1- Supply air pre-cooler.....	20
Data Analysis.....	20
Evaluation	24
Recommendations.....	27
ERC2 – Condenser Air Pre-Cooler	28
Data Analysis.....	29
Evaluation	32
Instructive Performance Problems	33
Recommendations.....	37
ERC3 – Integrated Combination	37
Data Analysis.....	37
Evaluations.....	41
Recommendations.....	44
REFERENCES	45

Figures

Figure 1 – Schematic of Multiple Stage Indirect Evaporative Heat Exchanger 6

Figure 2 – Psychrometric processes of Multiple Stage Indirect Evaporative Cooling 6

Figure 3 - Illustration of ERC2 7

Figure 4 – Psychrometric process of direct evaporative cooling 8

Figure 5 – An example of equipment using ERC3 technology. 9

Figure 6 – Psychrometric chart showing the thermodynamic paths of the ERC3 technology..... 9

Figure 7 – ERC1 Measurement points..... 13

Figure 8 – ERC2 Measurement points..... 14

Figure 9 – ERC3 Measurement points..... 15

Figure 10 – Screen shot of compiled raw data 17

Figure 11 – Screen shot of Averaged Hourly Data..... 18

Figure 12 – Example Regression Analysis Plot..... 18

Figure 13 - Outside air temperature v. cooling capacity and efficiency of 10-ton RTU 19

Figure 14 – ERC1 Pre- and post- regression analysis..... 21

Figure 15 – ERC1 Total dining room HVAC power Pre- and post-installation 22

Figure 16 – ERC1 Psychrometric chart 23

Figure 17 – Measured evaporative effectiveness of ERC1..... 23

Figure 18 – ERC1 Measured temperatures and power consumption on example afternoon 24

Figure 19 – ERC1 Calculation Model Calibration..... 25

Figure 20 – Comparison of ERC1 Technology eQuest run results 26

Figure 21 – Lab Testing showing impact of Outdoor Air on RTU Performance normalized to 95°F rating temperature 29

Figure 22 – ERC2 retrofitted RTU pre and post installation power vs. outside air dry bulb temperature 30

Figure 23 – Total building HVAC power pre and post-installation comparison between two similar weather days..... 31

Figure 24 – Psychrometric chart showing the thermodynamic path of the ERC2 processes 32

Figure 25 – Linear regression developed for the ERC2 installation at site #2..... 34

Figure 26 – ERC2 site #2 Psychrometric chart 35

Figure 27 – ERC2 site #2 Photo of Bypass 36

Figure 28 – Psychrometrics of Site #3 showing no water added 36

Figure 29 – Total kW Demand of RTUs measured pre- and post-
installation of the ERC3 technology Site #6 38

Figure 30 – Energy demand of an ERC3 retrofitted RTU..... 39

Figure 31 – Psychrometric states and evaporative cooling
effectiveness of condenser air with respect to outside
air temperature..... 40

Figure 32 – Supply air temperatures of the retrofitted units (#16,
17, and 19) 40

Figure 33 – Regressed pre- and post-Installation total energy
usage of RTUs Site #5 42

Figure 34 – Algae growth and calcium build-up was observed on
the direct evaporative cooling media 43

Tables

Table 1: Tested sites 11

Table 2: Savings Summary for Measured and eQuest Results 26

Table 3: Average Indirect Section Evaporative Effectiveness..... 41

Equations

Equation 1. Effectiveness for evaporative components5

EXECUTIVE SUMMARY

PROJECT GOAL

The project goal was to measure and quantify the energy savings associated with the installation of three categories of evaporative retrofit components for roof top units (RTUs) and to develop generic performance specifications and procedures to use in customized and deemed energy efficiency programs.

The major benefit of evaporative retrofit components for RTUs is the reduction of peak power consumption during hot weather conditions when the electric grid is heavily loaded by air conditioning equipment. Thus the testing also focused on making peak demand reduction assessments.

Generic performance specifications are needed for each technology. This report covers the field testing examples of each technology. The testing is not intended to compare a particular technology to another, thus efforts have been made to avoid naming manufacturers, equipment makes, or model numbers. To this end graphics have been simplified and installation pictures minimized.

PROJECT DESCRIPTION

In this study, three emerging evaporative cooling technologies were evaluated using the field test results obtained from six test sites. They are: 1) Outdoor Air Supply (OAS) evaporative pre-cooling; 2) condenser air evaporative pre-cooling; and 3) integrated systems implementing both 1 and 2. Savings are achieved either by reducing the cooling load on the RTU compressor(s) because supply air is pre-cooled or by increasing the vapor compression cycle efficiency because condenser air is cooled by direct evaporation.

PROJECT FINDINGS/RESULTS

The test results indicate that the technologies are ready for commercial adoption; however, lab tested performance and proper design and installation are critical. Correct installations of the evaporative technologies provided both demand and energy consumption savings. The percentage savings from demand reduction is higher than for energy savings because the efficiency of the evaporative technologies increases with the dry bulb temperature, which is typically highest when energy demand is greatest. This impact is accentuated in hot dry climates where the difference between the dry bulb and wet bulb temperatures (wet bulb depression) can exceed 30 or even 40° F. System design and HVAC operating hours have a significant impact on the overall savings. The tests also showed that improper site selection, installation and operation can jeopardize the savings and even create additional demand and consumption. Two of six sites showed no savings due to improper installation which informed the recommendations made in this report. The data analysis of the field test showed peak kW reduction as high as 60% and energy kWh savings as high as 70% depending on the application. Thus it is important to deploy these technologies correctly to realize their significant potential to improve the efficiency of existing RTUs.

PROJECT RECOMMENDATIONS

It is recommended that the three evaporative technologies presented in this study be considered for incentives as part of utility energy efficiency and demand reduction programs

to achieve higher market penetration and lower costs. It is important that site selection, installation, and commissioning be performed correctly by trained technicians following manufacturers' explicit procedures. Each site must also be operated and maintained to achieve the potential savings over time.

Laboratory or field testing will need to be required to qualify a product for an incentive program. The testing should include a test to verify the minimum evaporation effectiveness set by the program is being achieved. Evaporative effectiveness over a range of conditions should be established for use in computer simulation models that predict peak demand reduction and annual kWh savings. Products that qualify may be added to a list maintained by efficiency program implementers. Then post-installation and commissioning inspection should be conducted as a part of the incentive process. During the initial years of evaporative retrofit component programs, site verification inspections will be conducted at a higher rate which can decline based on experience. Finally, it is recommended that the incentive programs require a maintenance agreement be in place for three to five years following installation due the critical importance of maintenance.

INTRODUCTION

BACKGROUND

Evaporative cooling technologies studied in the project operate based on well-understood engineering principles to increase the efficiency of vapor compression cooling and reduce the cooling load on a commercial space. Nearly all large HVAC systems use evaporative condensers and cooling towers because of efficiency and capacity benefits on the order of 30%. Evaporative cooling components in commercial rooftop unitary packaged equipment (RTU) are rare and only available on special order from a few Original Equipment Manufacturers (OEM). There are hundreds of thousands of RTUs on commercial buildings. After quality maintenance¹ is instituted, these sites become candidates for evaporative retrofit components that can raise their efficiency very significantly, as well as reducing their peak demand. This project was initiated in recognition of this potential, with goal of bringing to market the next generation of evaporative equipment for RTUs.

A barrier to market uptake is that evaporative cooling has been implemented and maintained poorly in the past, giving all evaporative approaches a bad reputation. In the last ten years, however, manufacturers have made advances in developing technologies that can compete in the current market. This project uses the results of lab tests done by others and field testing done by the project to develop information that will support these technologies in achieving the level of market share justified by their performance.

The PG&E laboratory in San Ramon has completed seven (7) reports² on tests performed on direct, indirect, and indirect/direct evaporative cooling systems. Of particular interest to this project are two laboratory studies, (Robert Davis, 2006 and 2009) that tested the prior generation of indirect evaporative coolers which are included in the ERC1 category of technologies. Lab test results have provided valuable information and serve to establish the potential of a technology but a set of field tests were deemed necessary to incorporate

¹ ANSI/ASHRAE/ACCA Standard 180

² Davis, Robert, PG&E Applied Technology Services (ATS), San Ramon – see References

additional environmental, installation, and maintenance variables that cannot be tested in the lab. An example of the importance of lab tests is the work being done by UC Davis Western Cooling Efficiency Center on a method test for one of the evaporative retrofit component technologies.³ The process is underway that will result in an American Society of Heating, Refrigeration, and Air-conditioning Engineers (ASHRAE) Method of Test standard that will be used to establish the evaporative effectiveness of condenser air pre-coolers.

EMERGING TECHNOLOGY

The emerging technologies discussed in this paper are applications that use the cooling effect of evaporation water to reduce the power consumption of conventional RTUs. They have little resemblance to old-fashioned "swamp coolers." In various ways, these emerging technologies have overcome problems that limited the reach of evaporative cooling in the past. The evaporative retrofit components increase the efficiency of RTUs especially during high temperature conditions, which occur when the grid is more stressed. Therefore, they not only provide a benefit in term of energy savings and cost reduction to the customer, but also help the utilities to lower their peak demands. In this study, three evaporative retrofit component (ERC) technologies were considered:

- ERC1 - Indirect evaporative cooler for outside air: Entering outside air is cooled without gaining moisture by passing through the dry side of an evaporative heat exchanger⁴.
- ERC2 - Direct evaporative condenser air pre-cooler: Entering outside air is cooled by direct evaporation of water before entering the condenser coil. This is commonly referred to as pre-cooling condenser air.
- ERC3 - Integrated combination of ERC1 and ERC2: Outside air is cooled through the direct evaporation of water before entering the condenser coil, and make-up air is indirectly pre-cooled through the dry side of water to air coil or heat exchanger whose wet side contains evaporatively cooled water.

Since the ERCs also increase the capacity of the units, the number or size of RTUs can be reduced in cases of major retrofits. Also, the reduced discharge pressure on the high side of the refrigeration cycle should increase the equipment life, though the lifetime of package units is more often dictated by of a number of variables such as exposure to weather, salt air, etc. than by the operation of the units themselves.

ASSESSMENT OBJECTIVES

Many variations of evaporative technologies have been lab tested and field tested in the past, but, to our knowledge, there hasn't been a study done on all 3 categories of retrofit evaporative technologies. Therefore, the main objectives of this study are:

- To measure the energy and demand savings of different emerging evaporative RTU retrofit technologies,
- To understand and quantify the psychrometric processes of the technologies in field applications,

³ UC Davis Western Cooling Efficiency Center; *3rd Quarter 2012 News Letter*, p. 9
<http://wcec.ucdavis.edu/resources/newsletter/>

⁴ Recently an indirect/direct OAS technology was introduced with the possibility higher evaporative effectiveness controlled to provide an acceptable level of increased humidity.

- To compare field test results with lab test results,
- To identify a field measuring plan that could be replicated in the future for other evaporative cooling technology installations,
- Develop computer simulation models to estimate annual savings and compare them to eQUEST,
- To identify a possible deemed savings and incentive methodology for energy efficiency incentive programs.

This was a field study on the benefits of the evaporative retrofit components, the study did not address whether or not the performance matched the manufacturer specifications or if there was degradation in performance over time. The study was the comparison of the time periods where the only change was the addition of evaporative retrofit components.

With this evaluation, readers will be able to begin to assess these evaporative cooling technologies and be better equipped to advise their customers on their savings potential.

EMERGING TECHNOLOGY PRODUCTS

TECHNOLOGY

This study tested three types of products that employ evaporative cooling technologies. They are available from about 10 manufacturers, of which 5 were involved in these tests. For the ease of recall and to avoid manufacturer or product names, they will be referred to as ERC1, ERC2, and ERC3 in this report as listed above. These are applied to existing RTU or added to an RTU served space.

The definition of RTUs can be broad, but in this study we evaluated units of any packaged air conditioning Direct Expansion (DX) system with an air cooled condenser. Depending on the type of unit the typical RTU has a supply fan, compressor(s), condenser fan(s), and some type of integrated economizer.

Some of the technologies evaluated can also be used to retrofit air-cooled chillers, but these applications were beyond the scope of work for this study.

This study is called "Evaporative Retrofit Components for RTUs" because in most cases the technologies are add-ons. Only the ERC1 can be installed as a stand-alone system, replacing an existing RTU. In such cases, however, the whole air distribution system may need to be modified because the required airflow is increased. Although it will not happen in the immediate future, in many cases evaporative non-compressor-based technologies could potentially replace the compressor-based RTU technologies as they become economically feasible and are proven reliable.

THERMODYNAMICS

When air contacts water some of the liquid water evaporates to a gaseous state in the air stream. This process removes heat from the air and adds heat to the evaporated water. The rate of evaporation varies with the saturation of the incoming air. The rate can be increased by spraying the water as a fine mist to wet evaporative media that spreads the water over a large surface area. Heat is removed from the air stream and added to the water as it evaporates, thus lowering the dry bulb temperature of the air, which becomes cool and moist. As shown in the psychrometric chart in Figure 2, this process starts with the conditions of the incoming air, and moves up and to the left as the water evaporates, shown

by the dashed green line along the constant wet bulb line. For example, outside air at 95°F dry bulb and 67°F wet bulb that is evaporatively cooled to 75°F dry bulb would remain at 67°F wet bulb.

The three technologies presented in this study work differently even though they all are related to the cooling effect of water evaporation. For all three technologies presented, the evaporation efficiency⁵ or effectiveness is defined as follows:

EQUATION 1. EFFECTIVENESS FOR EVAPORATIVE COMPONENTS

$$Effectiveness = \left(\frac{T_{db,in} - T_{db,out}}{T_{db,in} - T_{wb,in}} \right) \times 100\%$$

Where:

T_{db} is the Dry Bulb Temperature

T_{wb} is the Wet Bulb Temperature

ERC1: The process for ERC1 is a multistage heat exchanging system in which the heat removed from the supply air stream is added to the working air stream, which is continuously cooled by the process of water evaporation. The evaporative process removes heat from the incoming outdoor air before it passes through the cool/wet side of the heat exchanger.

The airstream entering the evaporative unit is divided into two streams:

- a) The cool/wet airstream, referred to as working air, is cooled by the evaporation of water as it is blown through a wetted evaporative media with enough pressure to cause it to traverse the narrow wetted passages. Through this process, the working air is cooled toward the wet bulb temperature (path 1 to 3 in the Figure 1).
- b) The dry stream is referred to as the supply air stream, as it is cooled in the dry side of the heat exchanger without the addition of any moisture in the dry side of the heat exchanger, and delivered either directly to the space or to the RTU as makeup air (path 1 to 2 in Figure 1). Its temperature can approach the dewpoint (below wet bulb).

Figure 2 shows the processes on a psychrometric chart.

⁵ Sometimes referred to as "evaporative efficiency"

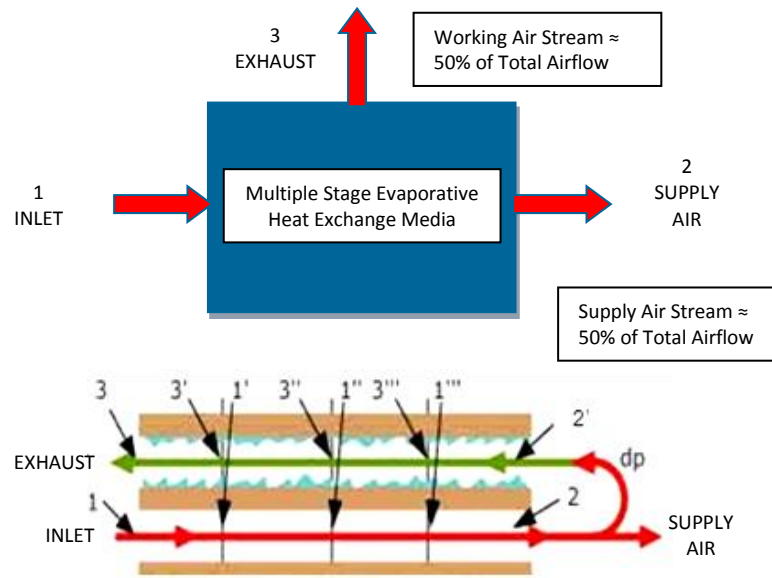
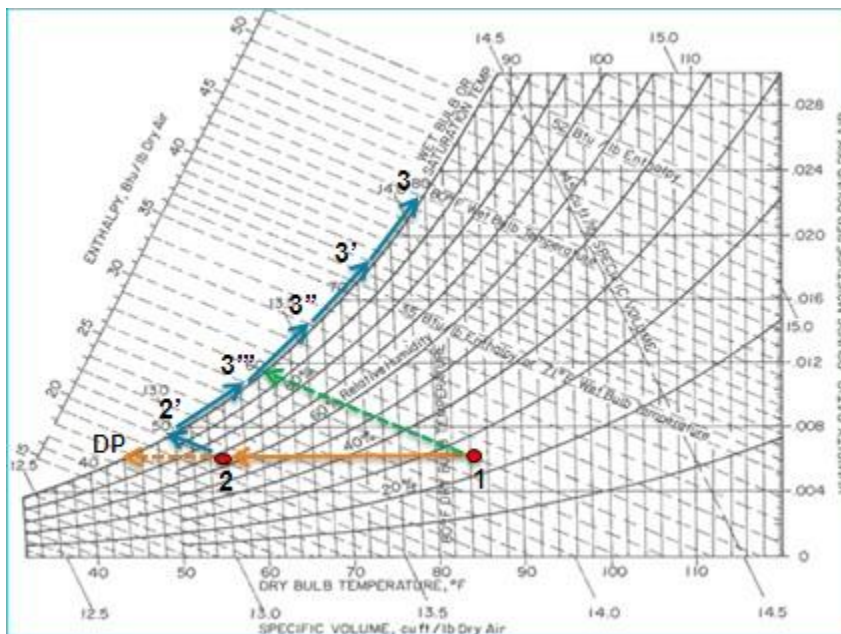

FIGURE 1 – SCHEMATIC OF MULTIPLE STAGE INDIRECT EVAPORATIVE HEAT EXCHANGER



- Blue line along the saturation temperature curve tracks multiple stages of cooling
- Dashed green highlights the wet bulb temperature line
- The horizontal orange line tracks the supply air temperature

FIGURE 2 – PSYCHROMETRIC PROCESSES OF MULTIPLE STAGE INDIRECT EVAPORATIVE COOLING

ERC2: ERC2 works by the principle of direct evaporative cooling of the outdoor air being drawn through the RTU condenser coil (Figure 3). The air going into the condenser coils is in direct contact with the water, therefore the condenser receives a cooler dry bulb

temperature as the result of water evaporation. As previously explained, the wet bulb temperature of the air does not change during this process (path 1 to 2 in Figure 4), and therefore the refrigeration cycle condenses at a lower temperature. Since the lower temperature means a lower pressure for the refrigeration cycle, the compressor discharges the high pressure hot gas at a lower pressure.

The water evaporation occurs on evaporative media or pads that can be made from a variety of different materials. A proven approach is to have thick rigid media in a frame placed in front of the condenser coil. The frame typically contains a sump with a pump that circulates water to a manifold above the media from which the water flows by gravity back down to the sump. The evaporative effectiveness is about 60 to 70%. ERC2 product tested by this project accomplishes the same effect by spraying water out of nozzles to wet the media pads. This approach holds the promise of lower installed costs.

One of the tested units has water supplied directly by the city pressure and is regulated to avoid dripping. This technology is "sump-less" and does not need a recirculation pump in normal circumstances, according to manufacturer instructions. Another tested ERC2 has a pump and a collection basin "sump" so that water is sprayed constantly onto the pads, allowing water that isn't evaporated to be collected and recirculated for reuse.

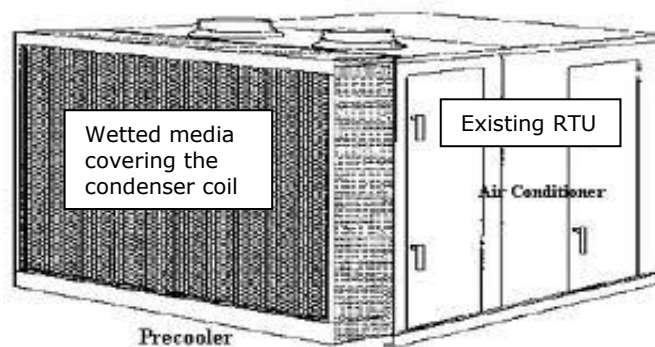

FIGURE 3 – ILLUSTRATION OF ERC2

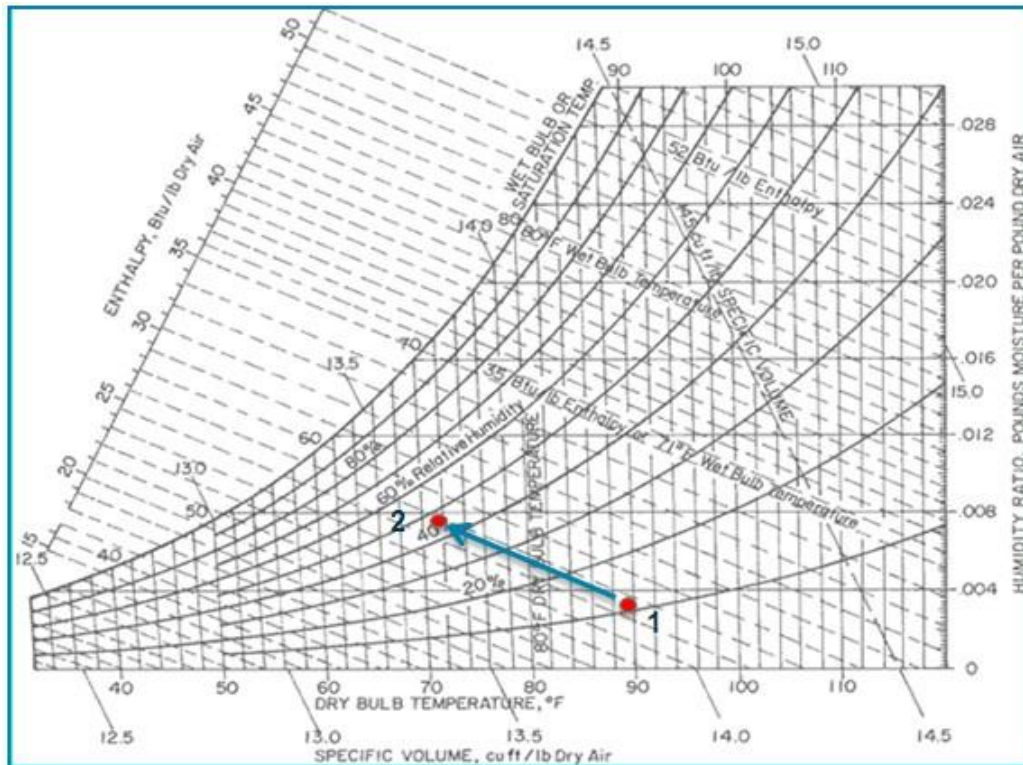

FIGURE 3 – PSYCHROMETRIC PROCESS OF DIRECT EVAPORATIVE COOLING

ERC3: Combines ERC1 and ERC2 in an integrated system. This system has three benefits: it reduces the makeup air load, increases the unit capacity, and increases the unit efficiency. ERC3 has a cooling tower type media. Water is pumped from a sump to the top of the media where it flows by gravity back to the sump thoroughly wetting the media at "A" in Figure 4. As a result, the condenser air that passes through the wetted media is evaporatively cooled (path 1 to 2 in Figure 6). The cooled air then passes through the condenser coils and is exhausted by the condenser fan(s). The excess water is collected into a sump and then pumped to a coil on the makeup air side at "C". The water, which is near wet bulb temperature, pre-cools the makeup air (air path 1 to 3 in Figure 6) before it enters the mixed air chamber of the RTU. The efficiency on the condenser side of this type of technology is defined by the same formula as the ERC2 technology. An alternative being explored by manufacturers of ERC1 is to place it at position "C" with result that air can be delivered.

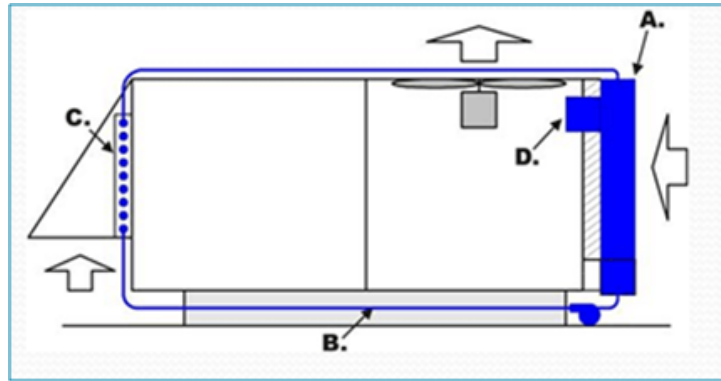

FIGURE 4 – AN EXAMPLE OF EQUIPMENT USING ERC3 TECHNOLOGY.

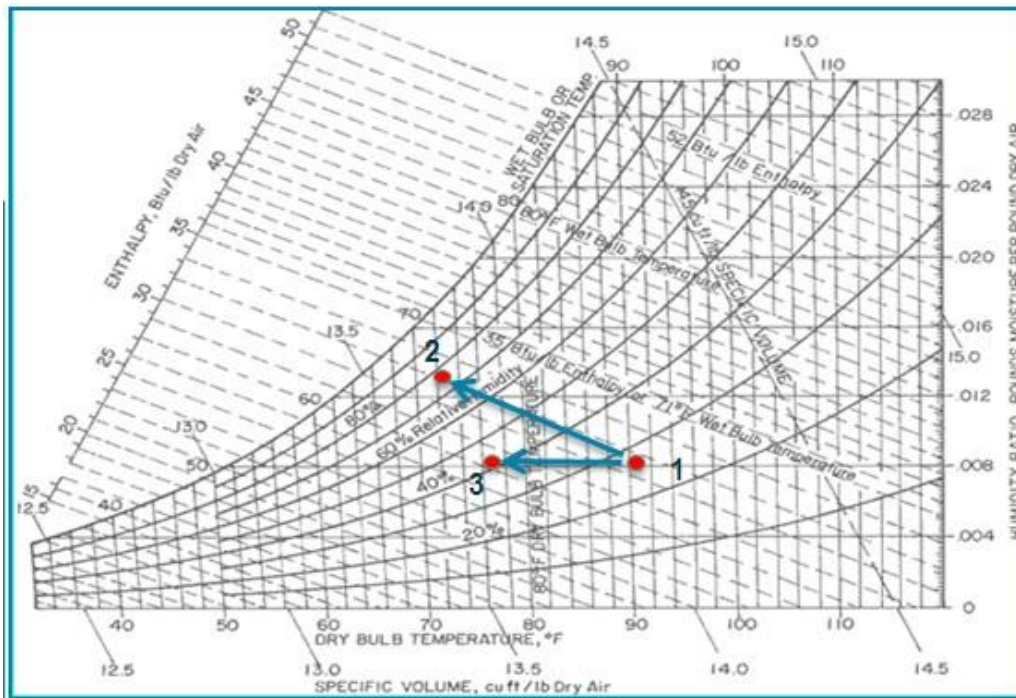

FIGURE 5 – PSYCHROMETRIC CHART SHOWING THE THERMODYNAMIC PATHS OF THE ERC3 TECHNOLOGY.

TARGET MARKETS

These technologies can be applied to virtually all market segments that have RTUs. However, big box retail stores and small- to medium-sized offices have historically used RTUs as opposed to chilled water plants. Therefore, those two market segments should be considered as the direct target of the evaluated technologies.

MARKET BARRIERS

There are a number of market barriers to all designs, including:

- Installation cost with more than 3 to 5 year simple payback from electricity savings,
- Uncertainties of the energy savings calculation methodology and the utility incentives that would reduce payback to 3 years or less,
- Lack of training for the HVAC design community that makes efficiency recommendations,
- Shortage of contractors and technicians trained in the installation and maintenance of water-based technology,
- Rate structure that is just starting to have demand charges for all commercial customers,
- Cost of bringing water onto the roof (if not already there),
- Maintenance that each system requires,
- Lack of familiarity with best practices for water quality and use management
- Regulations regarding water usage.
- Lack of understanding of the comparative water use of the saved electricity

TECHNOLOGY/PRODUCT EVALUATION

The three technologies previously described were tested as retrofits on existing RTUs in several field locations. Although laboratory tests and engineering principles showed that the technologies could be used to increase RTU energy efficiency, a field test protocol that included all of the variables was deemed necessary by the PG&E Emerging Technology Program Manager.

Eight test sites were originally selected and installations were completed in time to collect significant cooling-season data at six sites. This serves to remind us that HVAC retrofit decisions take time and persistence on the part of energy efficiency program implementers. The sites were selected based on climate zone, market segment, and most importantly, on customer willingness to install emerging technology equipment. In addition, the customer had to agree to facilitate prolonged performance monitoring. In some cases, incentives were paid, but never were close to 50% of the cost. Table 1 summarizes the sites and technologies selected:

TABLE 1: TESTED SITES

Site #	Location (CZ)	Market type	Existing equipment	ET equipment	Hours of operation
1	Rocklin (CZ11)	Restaurant	Two 4 ton RTUs and one 5 ton RTU service the open dining room	Add one ERC1 in addition to the existing three units. The ERC1 unit was integrated so that it supplies all OAS during the cooling season	7 am to 3 pm
2	Woodland (CZ12)	Office	Two 50 ton RTUs	Retrofit existing equipment with two ERC2	8 am to 5 pm
3	Vacaville (CZ12)	Office	Two 130 ton RTUs, one 75 ton RTU, and one 10 ton CRAC	Retrofit existing equipment with four ERC2 (of appropriate sizes for each application)	8 am to 5 pm CRAC 24/7
4	Fresno (CZ13)	Office	One 35 ton and one 50 ton RTUs	Retrofit existing equipment with two ERC2 (of appropriate sizes for each application)	8 am to 5 pm
5	West Sacramento (CZ12)	Big retail store	Three makeup-air-only air handlers and 35 RTUs of various sizes from 5 to 20 ton	Retrofit six 20 ton RTUs with ERC3 system, provide the makeup air with the retrofitted units, convert other RTU to heating and cooling only, and shut down the makeup air handlers	24/7
6	Woodland (CZ12)	Big retail store	35 RTUs of various sizes from 5 to 10 ton	Retrofit ten 10 ton RTUs with ERC3 systems	6 am to 12 am

TECHNICAL APPROACH/TEST METHODOLOGY

The technical approach to this study focused on understanding the field performance of the RTUs that were retrofitted with evaporative cooling technology. The field test was not intended to be a controlled-environment test, but rather a verification of what the customer impact would be. For that reason, power and current monitoring and regression analysis were used to compare the power consumption versus dry bulb outdoor temperatures before and after each of the installation. The psychrometric chart was used to map the thermodynamic process of the evaporative cooling and its effect on power consumption. All installations were thus monitored to evaluate the evaporation effectiveness and how it translated into energy and demand savings.

TEST PLAN

The test plan involved the measurement of all variables necessary to explain how the system works and how much energy can be saved. Specifically, multiple dry bulb and relative humidity measurement points were taken to reveal the psychrometrics of the evaporative cooling process while power and current monitoring of the units were taken and

correlated to the outside air conditions to quantify the savings. The measurement and verification performed for this study was done in accordance to the IPMVP Option A Retrofit Installation; key parameters measurement⁶ points and equipment used are detailed in the following sections.

BASELINE MONITORING

All sites were monitored for two weeks as a baseline with recording interval of five minutes. At sites #5 and #6 the RTUs that were not retrofitted continued to be monitored so that the performance of the site as a whole could be assessed. Sensor placement and type were the same for both the pre and post retrofit monitoring.

POST INSTALLATION MONITORING

Each site was subject to a different monitoring plan depending on the technology installed:

- ERC1 - For technologies that reduce the sensible load of the makeup air by lowering the dry bulb temperature:
 - Current⁷ for each RTU (with or without retrofit) serving the building or portion of building under consideration,
 - Current for each piece of supplemental equipment that the new technology added to the package or air handling unit (i.e. booster fan, pumps, etc...)
 - Outside air dry bulb temperature and relative humidity,
 - Dry bulb temperature and relative humidity of air supplied to the RTU air side economizer intake (for all the retrofitted units,
 - Supply air temperature for each retrofitted RTU serving the building or building portion under consideration.

⁶ IPMVP Volume 1 2009. p. 22.

⁷ Current transducers were used along with assumptions about voltage and power factor. Since the data is the difference between before and after the assumptions cancel if voltage and power factor remain essentially the same. This approach was deemed to be appropriate for the scope of the project and the sensitivity of the simulation models where variations of voltage and power factor are not considered. On 3 phase systems one of the legs was measured which assumes that the legs were close to being balanced. The same leg was measured before and after the installation.

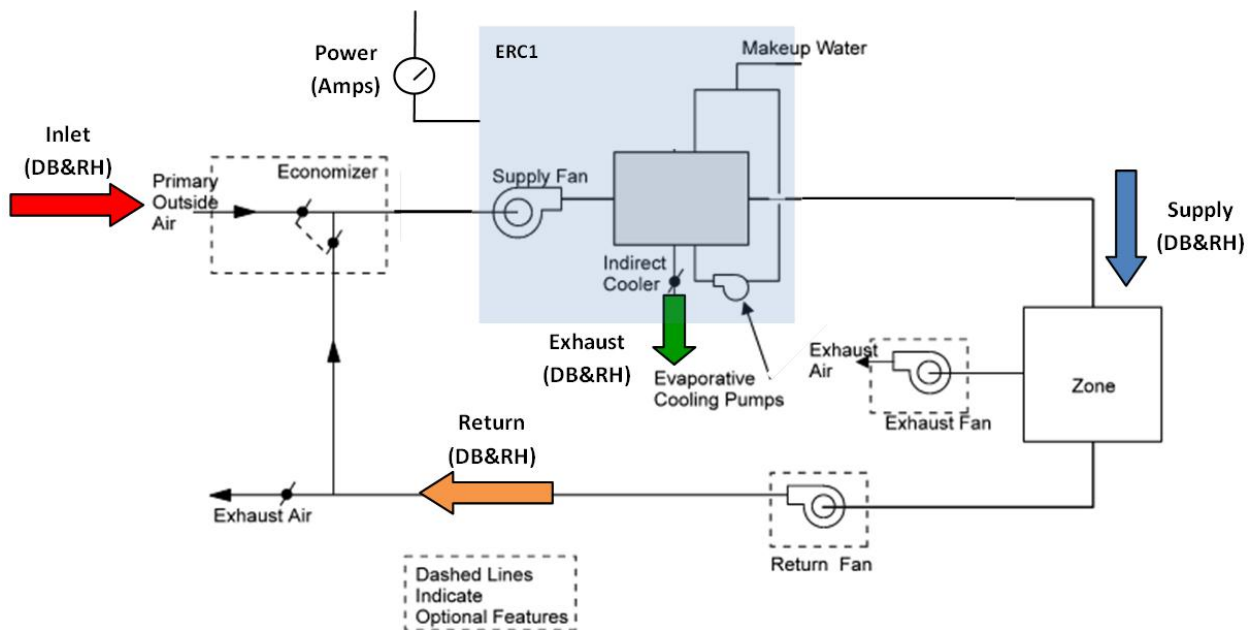

FIGURE 6 – ERC1 MEASUREMENT POINTS⁸

- ERC2 - For technologies that increase the vapor compression efficiency by lowering the condensing temperature:
 - Current for each unit (retrofit or not) serving the building or portion of building under consideration,
 - Outside dry bulb air temperature and relative humidity,
 - Dry bulb temperature and relative humidity of the air leaving the condenser coils for all the retrofitted units.

⁸ Diagram adapted from DOE-2.2, p. 380.

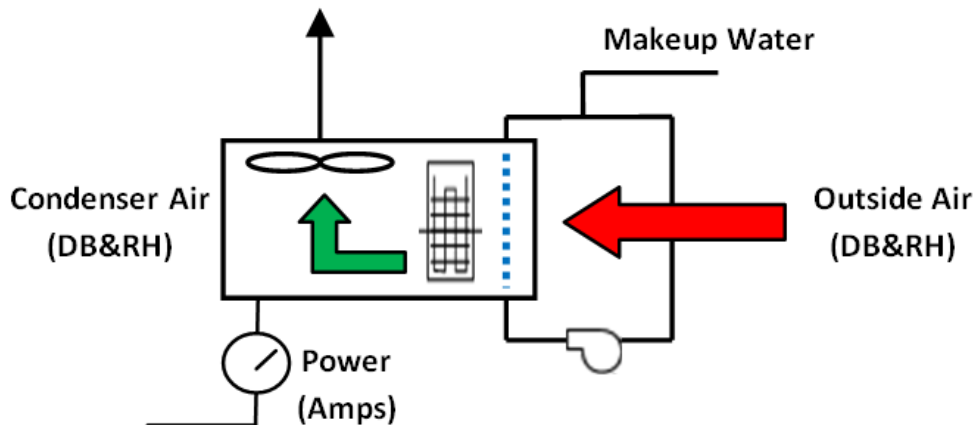
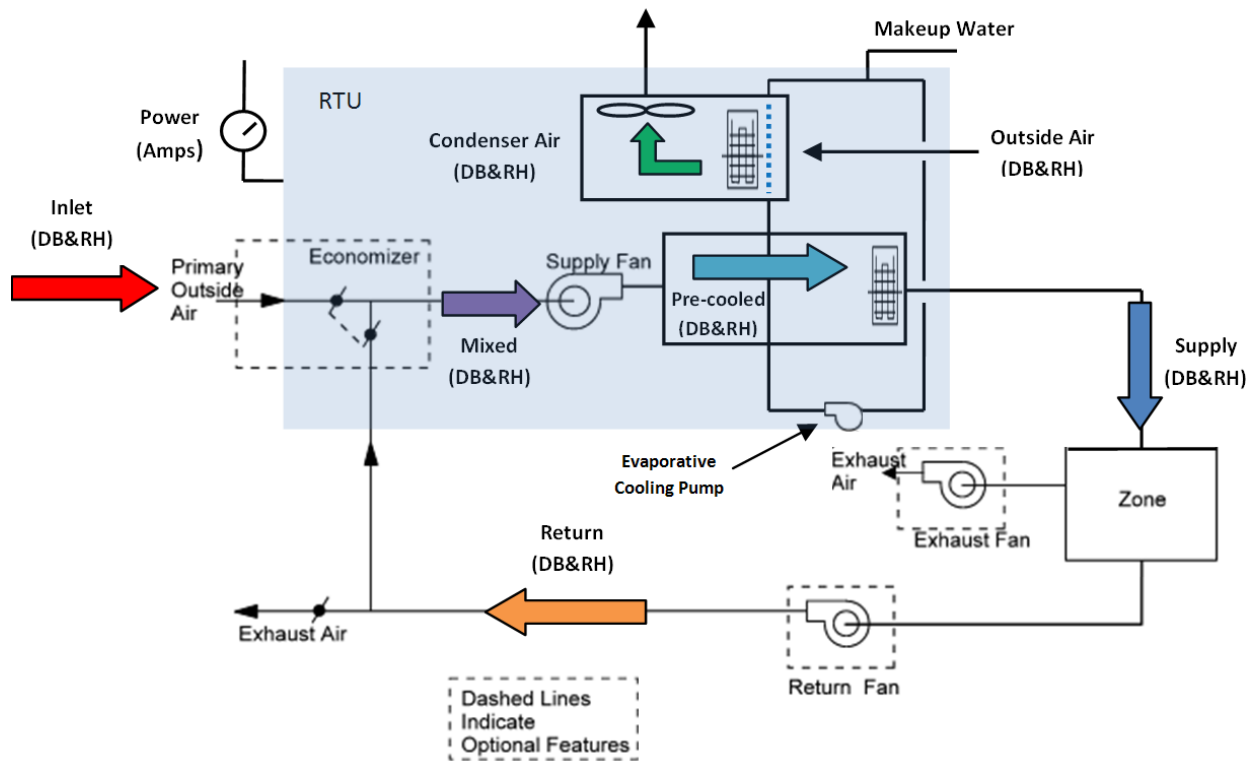

FIGURE 7 – ERC2 MEASUREMENT POINTS

- ERC3 - For technologies that reduce the sensible load of the makeup air by lowering the dry bulb temperature and increasing the efficiency of the vapor compression cycle:
 - Current for each RTU (whether or not it will be retrofitted or has been retrofitted by the evaporative technology) serving the building or building portion under consideration,
 - Current for each piece of supplemental equipment that the new technology added to the RTU (i.e. booster fan, pumps, etc.)
 - Outside air dry bulb temperature and relative humidity,
 - Temperature of the air supplied to the RTU air side economizer intake (dry bulb and relative humidity) for all the retrofitted units,
 - Temperature of the air leaving the condenser coils (dry bulb and relative humidity) for all the retrofitted units,
 - Return air temperature for each retrofitted unit,
 - Mixed air temperature for each retrofitted unit,
 - Supply air temperature for each retrofitted unit

Due to memory limitation of the loggers used, the logged data was downloaded multiple times for sites where the post-monitoring periods exceeded one month. This allowed monitoring personnel to inspect the site and report if any problems were present.

FIGURE 8 – ERC3 MEASUREMENT POINTS⁹

INSTRUMENTATION PLAN

The following summarizes the instruments used and data collected at each site:

Site 1 - 4 existing units and the installation of an additional ERC1:

- 5 current transducer: (2) 20 amps and 3 (50) amps,
- 5 external channel loggers (current),
- 1 OAT temperature logger (DB&RH) + 2 (SA on ERC 1 unit) + 1 (exhaust air on ERC1 unit) + 4 (SA) + 4 (RA) = 12 temperature and relative humidity loggers.

Site 2 - 2 air-cooled chillers:

- 2 current transducers: (2) 600 amps,
- 2 external channel loggers (current),
- 1 (OAT & RH) + 4 (post evaporative media) = 5 temperature and relative humidity loggers.

Site 3 - 3 air-cooled chillers, 1 split system DX CRAC unit:

- 4 current transducers: (2) 200, and (2) 600 amps,
- 4 external channel loggers (current),
- 1 (OAT and RH) + 6 (post evaporative media) = 7 temperature and relative humidity loggers.

⁹ Diagram adapted from DOE-2.2, p. 380.

Site 4 - 2 air-cooled chillers:

- 2 current transducers: (2) 200 amps,
- 2 external channel loggers (current),
- 1 (OAT & RH) + 4 (post evaporative media) = 5 temperature and relative humidity loggers.

Site 5 - 38 roof top units (6 retrofitted):

- 38 current transducers: (10) 20, and (28) 50 amps,
- 38 external channel loggers,
- 1 (OAS)+6 (post economizer coil)+ 6 (post evaporative media)+6 (return air)+6(mix air) = 25 temperature and relative humidity loggers,
- 15 (SAT) temperature loggers,
- 6 (sump water temperature) = 6 external channel loggers and 6 temperature probes.

Site 6 - 32 roof top units (6 retrofitted):

- 32 current transducers: (10) 20 and (22) 50 amps,
- 32 external channel loggers,
- 1 (OAT)+10 (post economizer coil)+ 10 (post evaporative media)+4 (return air)+ 10(mix air) = 35 temperature and relative humidity loggers,
- 32 (SAT) temperature loggers.

Current transducers connected with the loggers have an accuracy of $\pm 4.5\%$ of the full scale. Temperature loggers have an accuracy of ± 0.63 °F in measuring the dry bulb and 2.5% in measuring the relative humidity¹⁰. For the long term monitoring, the current of one leg of the 3 phase RTU was monitored. True power monitoring was performed at the beginning of the monitoring periods to identify the power factor, which ranged from 65% to 85% depending on the unit. This one-time measured power factor and voltage were used in the analysis. Data was recorded every minute at site #1, 2, 3, and 4, while data were recorded every three minutes at sites #5 and 6. The measured data were then compiled and averaged every 10 minutes, half an hour and an hour.

ANALYSIS METHODOLOGY

1. Downloading and Compiling Data

Temperature, relative humidity, and current data were collected with a time stamp every one, two, or six minutes depending on the installation. The data were then downloaded from the measuring equipment and compiled in a database. No modification was made to the temperature and relative humidity data, but measured currents were used to calculate 3-phase power with the following formula before placed into the database:

$$P = \sqrt{3} \cdot V \cdot I \cdot PF$$

where:

P = Power

¹⁰ Manufacturer specifications <http://www.onsetcomp.com/products>

	A	B	C	D	E	F	G	H	
1	Begin Date (5/24/12 16:00 or later):	End Date (11/10/12 10:24 or earlier):	Units: (e.g. 5,19 or All)		Get Data				
2	5/24/2012 16:00	9/10/2012 9:00	all						
3	Intervals								
4	<input type="radio"/> 1 Minute	<input type="radio"/> 2 Minutes	<input type="radio"/> 3 Minutes	<input type="radio"/> 6 Minutes	<input type="radio"/> 12 Minutes	<input type="radio"/> 30 Minutes	<input checked="" type="radio"/> Hourly	7	
5									
6									
7									
9	Date	Month	Day	Hour	Minute	OA RH%	KW1	KW2	
10	5/24/2012 16:00		5	24	16		20	4.1	5.7
11	5/24/2012 17:00		5	24	17		26	3.7	5.1
12	5/24/2012 18:00		5	24	18		29	5.6	5
13	5/24/2012 19:00		5	24	19		31	5	4.2
14	5/24/2012 20:00		5	24	20		35	4.2	3.9
15	5/24/2012 21:00		5	24	21		40	1.5	3.7
16	5/24/2012 22:00		5	24	22		44	1.4	3.6
17	5/24/2012 23:00		5	24	23		46	0.7	2.8
18	5/25/2012 0:00		5	25	0		52	1.4	2.9
19	5/25/2012 1:00		5	25	1		54	1.3	2.4
20	5/25/2012 2:00		5	25	2		53	0.7	2.7
21	5/25/2012 3:00		5	25	3		52	0.1	2.2
22	5/25/2012 4:00		5	25	4		51	0.8	2.7

FIGURE 10 – SCREEN SHOT OF AVERAGED HOURLY DATA

3. Regression Analysis

Most of the comparisons were done by plotting the outside air dry bulb temperature on the x axis and calculated power consumption on the y axis (as many charts in this report show). Using the spreadsheet regression/trend analysis function, the relationship between the outside air dry bulb temperature and the power consumption was obtained from the measured data as shown in Figure 12.

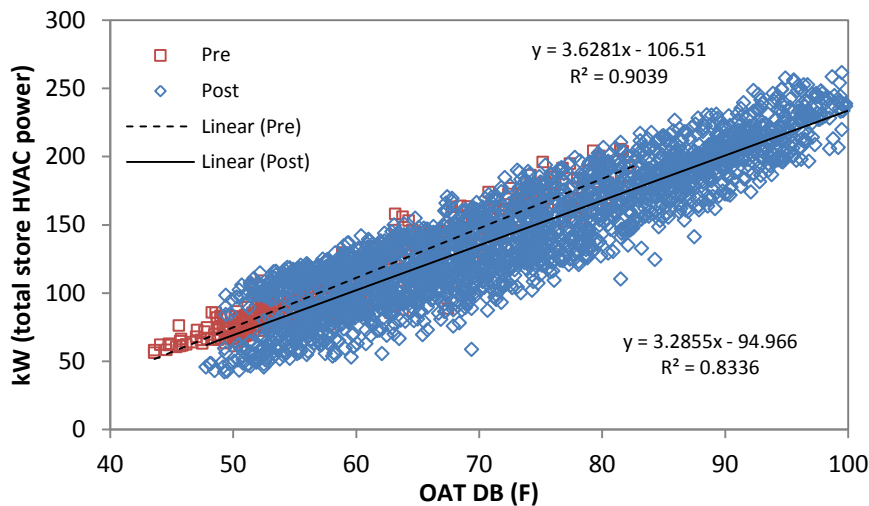

FIGURE 11 – EXAMPLE REGRESSION ANALYSIS PLOT

4. Hourly Analysis and Annual Savings Calculations

Since the measurements were taken for a limited number of hours, the annual power consumption was calculated using the hourly weather data. AESC developed calculators applicable for each technology, but the basic principles are the same and outlined below.

- a) First, the regression obtained from the pre-installation data was used to establish the baseline power consumption of the RTU units. Since the power consumption data was trended as a function of outside air dry bulb temperature, hourly power consumption of the baseline unit was calculated using the hourly outside air dry-bulb temperatures obtained from weather data. The annual power consumption of the existing units was calculated as the sum of all hourly usages.
- b) Next, the nameplate information of the RTUs, namely kW/ton, was used to establish the baseline load (see Figure 13). For indirect cooling technology, the measured average of the evaporative effectiveness, assumed constant, was used to calculate the pre-cooled air temperature using hourly dry-bulb and wet-bulb temperature data. Since the cooling load is proportional to the temperature differential, pre-cooling outside air results in a load reduction from the baseline. In the case of direct cooling technology, the measured evaporative effectiveness, also assumed constant, was used to calculate the hourly pre-cooled condenser entering air temperature, which was then used to calculate the cooling capacity increase. As shown in below Figure 13, the cooling capacity of an RTU increases with decreasing condenser entering air temperature.

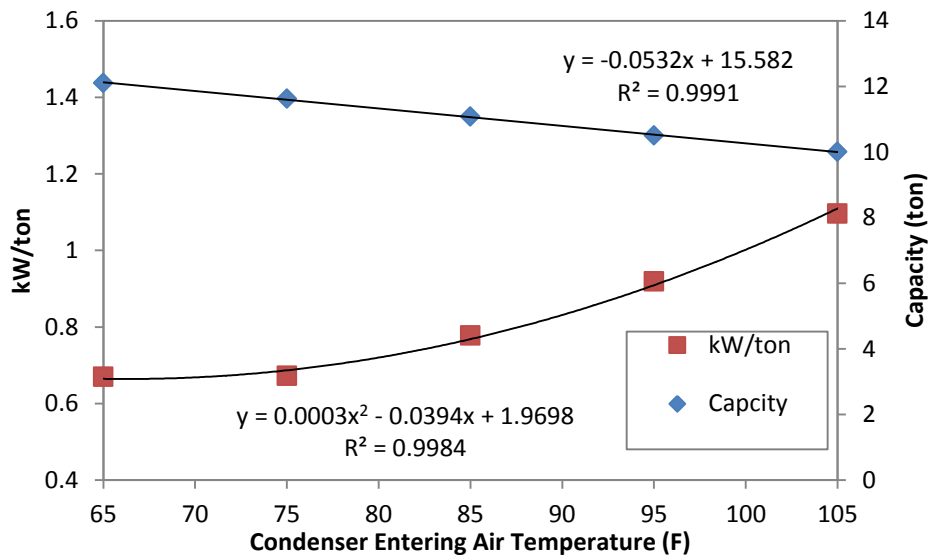

FIGURE 13 - OUTSIDE AIR TEMPERATURE V. COOLING CAPACITY AND EFFICIENCY OF 10-TON RTU

- c) The post-installation hourly power consumptions were then calculated from the reduced load and/or increased capacity calculated in previous step. Since the evaporative cooling technologies studied in this paper are add on units, the efficiency curve of an RTU remains the same for pre and post. However, reduced

condenser entering air temperature as well as part load operations (from the reduced load) result in increase in efficiency as depicted in 13. Note that educated estimates appropriate for each site were used whenever necessary to determine unknown variables, such as cooling set point, supply air temperature set point, and % outside air intake.

- d) Finally, the annual savings were calculated as the summation of hourly power consumption differences.

$$\text{Annual Savings (kWh/yr)} = \sum_{i=1}^{8760} (P_{i,pre} - P_{i,post})$$

For verification purposes, the calculated results were compared to measured results. As shown in Figure below, the modeled results are in good agreement with the regressions obtained from the measured data. The disagreement between measured and calculated (modeled) power consumptions during the post-installation is likely due to operating issues not captured in the calculator (i.e. calcium built-up on the evaporative media, imperfect sequencing, etc.), which will be discussed in the following sections.

RESULTS

Because of the differences in the three technologies, the results were divided into three sections so that data analysis, evaluation, and recommendations specific to each technology could be made separately.

ERC1- SUPPLY AIR PRE-COOLER

DATA ANALYSIS

At Site #1 an ERC1 type unit was installed as a cooling season Dedicated Outdoor Air Supply (D.OAS) addition to the 3 existing RTUs (2- 4 ton and a 5 ton unit) all of which serve the restaurant dining room.

The kWh power consumption of the 3 RTUs and one ERC1 unit were calculated from the measured data using the average kW demand over each hour that was monitored. The total power consumption of the equipment before and after the installation of ERC1 unit is scatter-plotted in Figure 14 with outside air dry bulb temperature on the horizontal axes. Because of the limited operating hours of the restaurant dining room (7am to 3 pm), only data during those hours was analyzed. From the two data sets (pre- and post- installation), two regression lines were developed based on dry bulb outside temperature. For the pre-installation data, linear regression resulted in a coefficient of determination (R^2) value of 0.77. The post-installation regression of total power versus outside air dry bulb temperature resulted in a second degree equation with 0.62 R^2 value. The two equations were then compared for the operating hours of the restaurant for any temperature above 60°F. At 90°F the kWh is dropped from 13.5 to 5 which is a reduction of 63%.

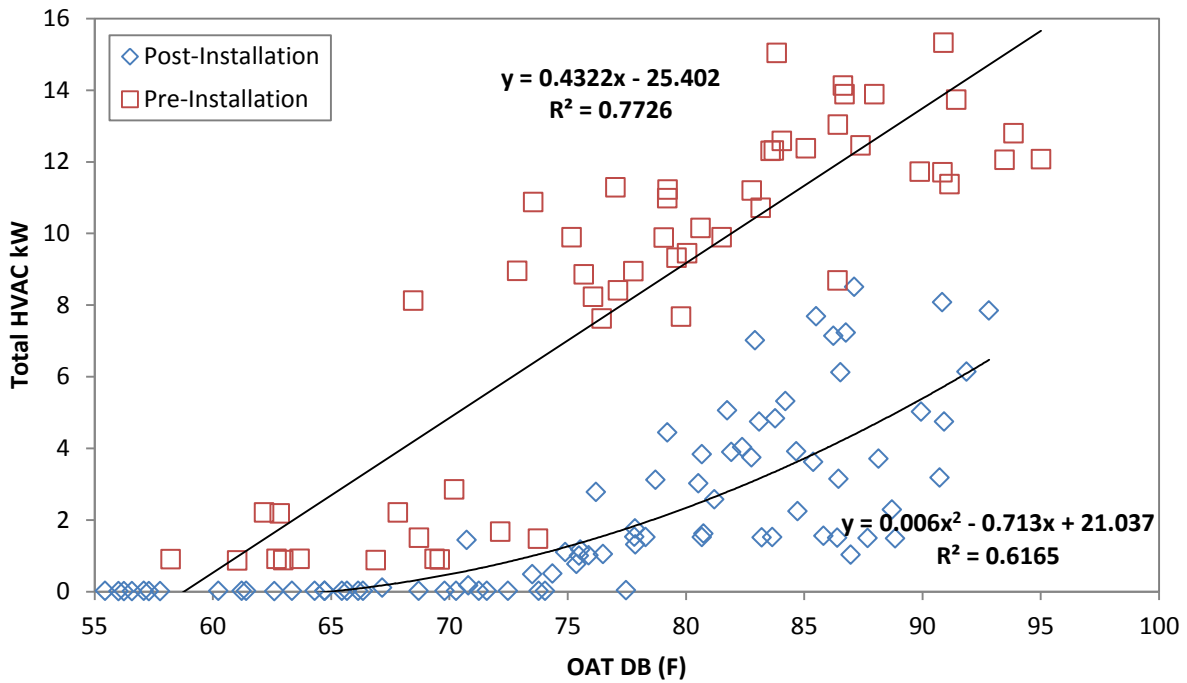

FIGURE 14 – ERC1 PRE- AND POST- REGRESSION ANALYSIS

In order to get a better understanding of the benefits of the newly installed ERC1 type unit, a time-power comparison was made between two similar weather weeks. The results showed that the ERC1 behaved as an extended air side economizer. Since the ERC1 was able to carry the load until the outside temperature was approximately 80°F, the package units ran less frequently and only during the hottest hours. The ERC1 unit runs at 1.8 kWh and is essentially constant. When additional cooling is needed kWh goes up dramatically as the RTU controllers turn on compressors and fans as shown in Figure 15.

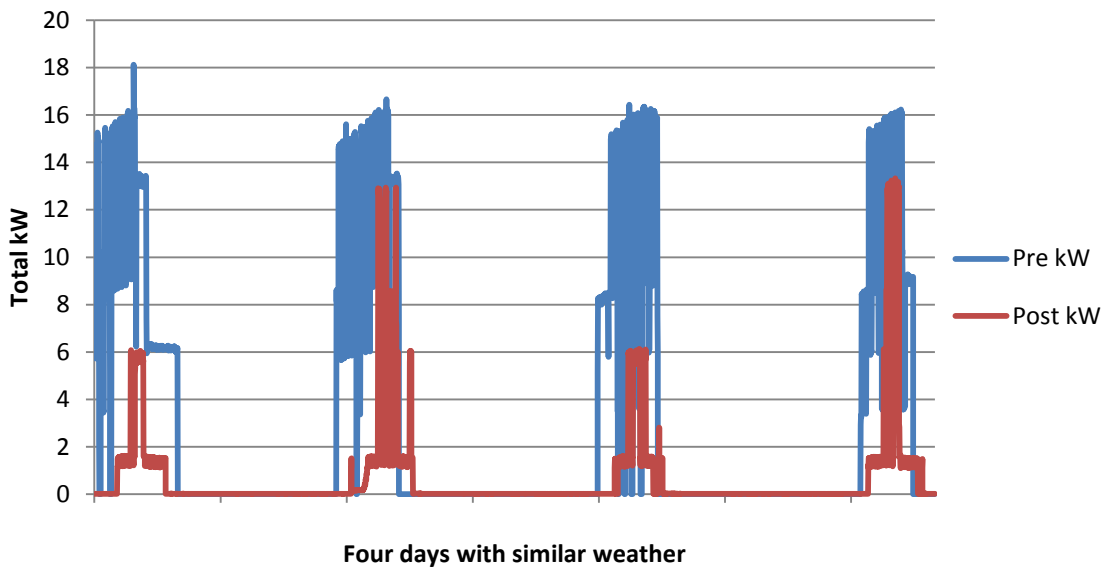

FIGURE 15 – ERC1 TOTAL DINING ROOM HVAC POWER PRE- AND POST- INSTALLATION

Analysis dedicated only to the ERC1 unit was conducted to understand the relationships among temperatures, psychrometric processes, and power consumption. From the psychrometric chart below (Figure 16), it can be seen that the supply air temperatures stayed relatively constant in the 57 to 67°F range while outside air temperatures varied widely from 68 to 95°F. On average, the ERC1 unit was able to cool the outside air by 22°F from 83 to 61°F. This is because the test was conducted in Climate Zone 11, which has relatively constant dew point temperatures during hot days resulting in large wet bulb depressions. ERC1 technology had evaporative efficiency high enough to reduce the supply air temperature close to or even below wet bulb temperature even when the ambient dry bulb temperature was nearing 95°F during the hottest hours of the test period. This is in agreement with the laboratory testing done by PG&E by Applied Technology Services which found that multiple stage indirect evaporative coolers delivered air at temperatures at or below wet bulb.¹¹

¹¹ Davis, Robert, ATS Report No.: 491-09.12, p. 9

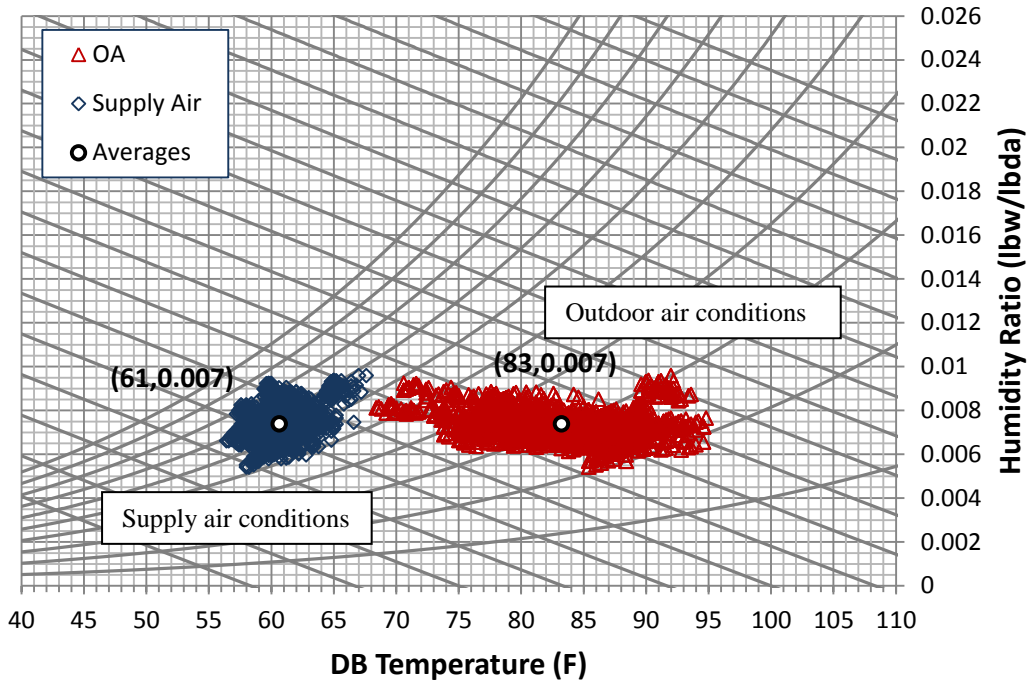

FIGURE 16 – ERC1 PSYCHROMETRIC CHART

From the psychrometric chart, the evaporation effectiveness of this technology with respect to the wet bulb temperature (Figure 17) was calculated to be 110% which shows that the unit tested has been improved since the model used in the 2009 testing by Robert Davis. The evaporation effectiveness with respect to the dew point was calculated to be approximately 65%.

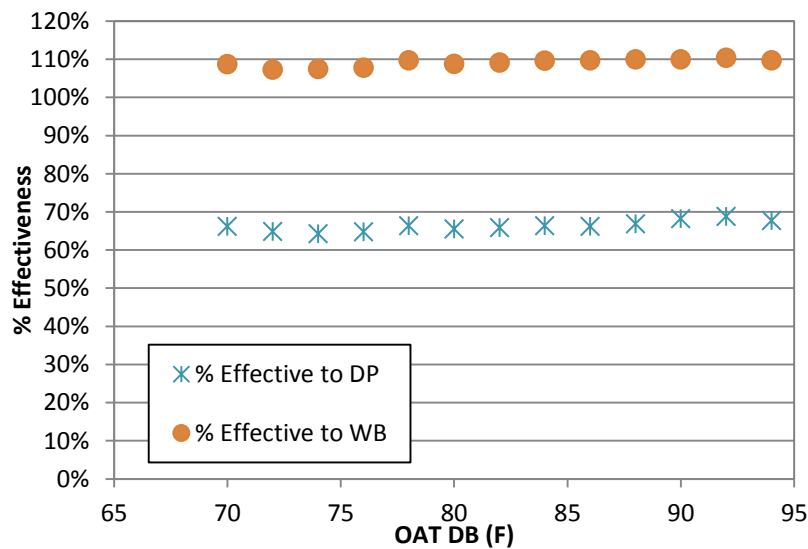

FIGURE 17 – MEASURED EVAPORATIVE EFFECTIVENESS OF ERC1

Figure 18 plots the hourly performance before and after ERC1 was installed on two similar days. The top dashed black line shows a steady increase in demand by the three (3) RTUs

that tracks the afternoon temperature rise. In contrast is the bottom solid light blue line showing that the ERC1 had no change in power consumption as is expected since only a fan is operating. This occurs while the indirect supply air remains between 60 and 65F tracking the web bulb temperature.

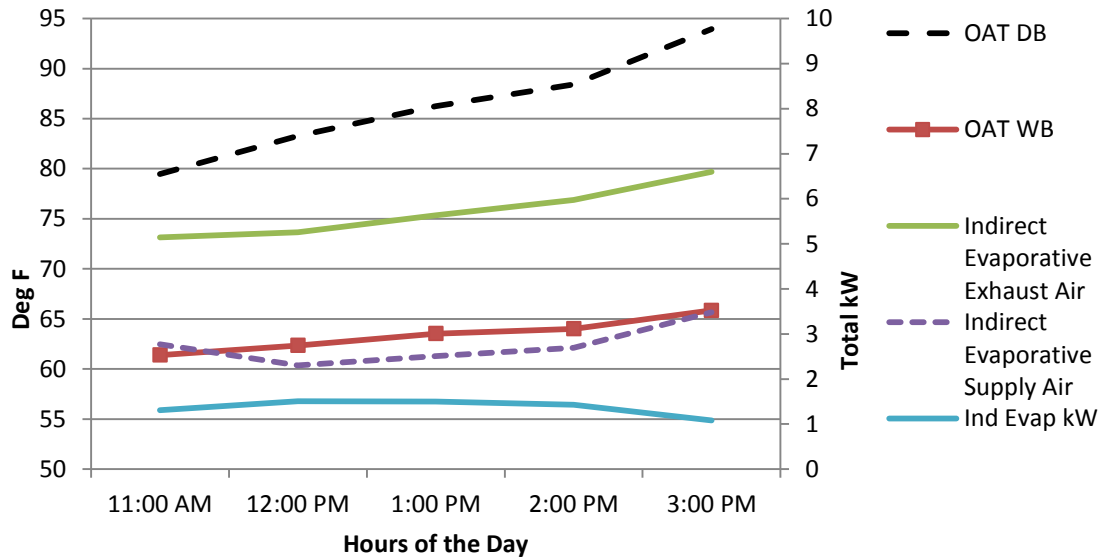

FIGURE 18 – ERC1 MEASURED TEMPERATURES AND POWER CONSUMPTION ON EXAMPLE AFTERNOON

It should be noted out that the exhaust or working air temperature of ERC1, plotted as the solid light green line, was still cooler than the outside air. Therefore, as a suggestion for future equipment integration, the exhaust air could be added to the condenser airstream for an RTU.

EVALUATION

Field test results were aligned with the laboratory tests done on an earlier ERC1 model by the same manufacturer. To assess the annual savings the method developed by AESC using spreadsheet software as described in *Hourly Analysis and Annual Savings Calculations* section above. As shown in Figure 19 the method yields a very good fit to the field data and allows an annual estimation of savings to be made.

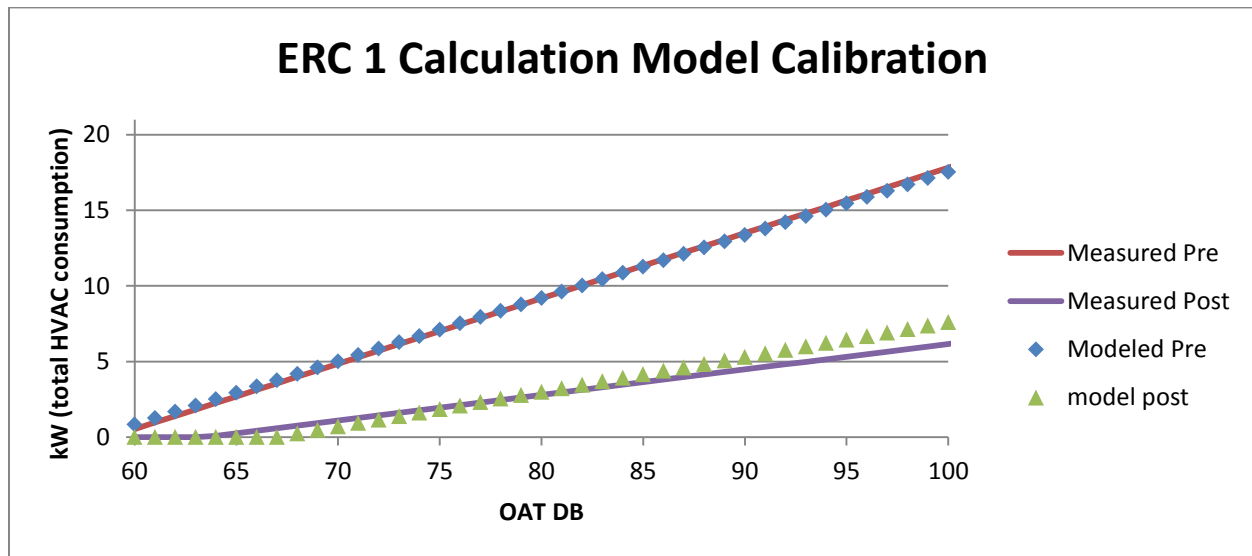

FIGURE 19 – ERC1 CALCULATION MODEL CALIBRATION

In order to expand the use of the field data to energy efficiency programs DOE2.2 computer simulations are used to estimate annual impacts of technologies using algorithms that estimate the performance of the technology. The DOE2.2 simulation program is used for Workpapers in support of Energy Efficiency programs and is readily available as the eQUEST program.¹² Documentation of the available methods for modeling evaporative cooling components lists the following options¹³:

DIRECT-EFF

Rated nominal effectiveness of the direct evaporative cooler. For variable-volume systems, this value is modified by a default curve of effectiveness vs. flow (which can be overridden using DIRECT-EFF-FFLOW).

DIRECT-EFF-FFLOW

For variable-volume systems, takes the U-name of a quadratic curve that modifies the rated effectiveness of the direct evaporative cooling element as a function of the flow rate.

INDIR-EFF

Rated effectiveness of the indirect evaporative cooler. For variable-volume systems, this value is modified by a default curve of effectiveness vs. flow (which can be overridden using INDIR-EFF-FFLOW).

INDIR-EFF-FFLOW

For variable-volume systems, takes the U-name of a quadratic curve that modifies the rated effectiveness of the indirect evaporative cooling element as a function of flow rate.

The default curve is for an older generation of ERC1 with evaporative effectiveness in the 60% range and so the last option is implemented using the curve fit equation from the data. The restaurant dining room being served by ERC1 was modeled using eQUEST. The effort was not to get the best match of the field data but to use normally available site information as input to the simulation. The hourly output from eQUEST is plotted in Figure 20 in same format as used for the field data shown in Figure 14.

¹² LBNL, DOE2.2 <http://doe2.com/>

¹³ LBNL, DOE2, p. 381

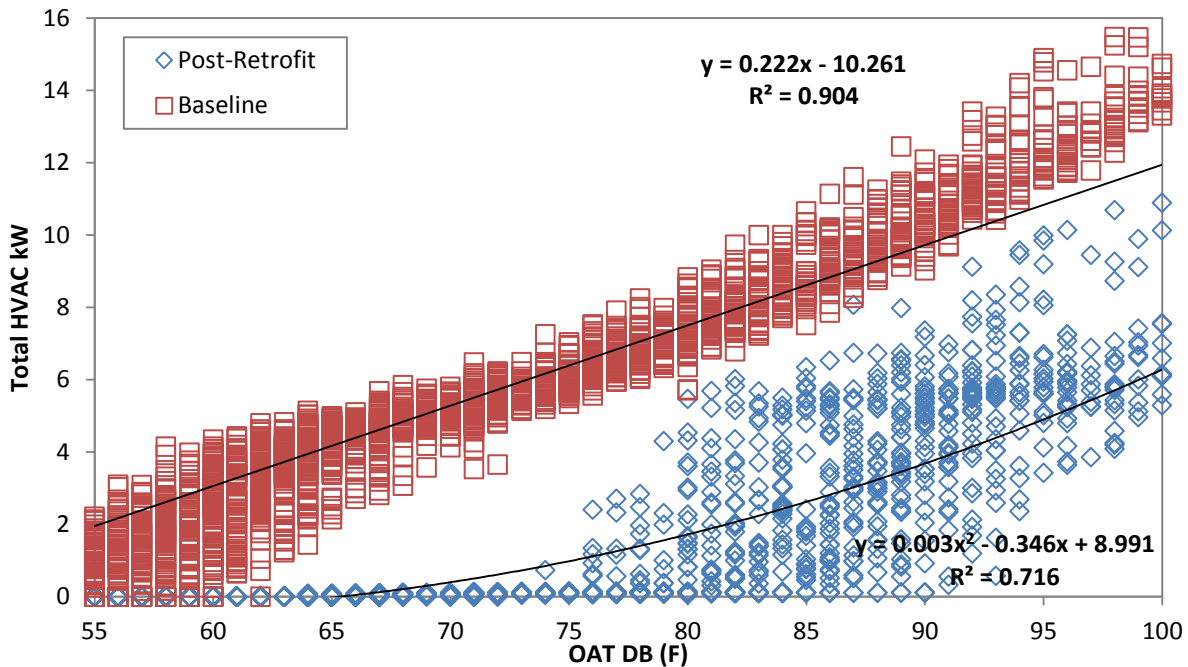

FIGURE 20 – COMPARISON OF ERC1 TECHNOLOGY eQUEST RUN RESULTS

The field data was matched using the AESC method as it was designed to do while the eQUEST output is not matched to the site but is more generic. To compare the two methods the final results are shown in Table 2. The Baseline consumption is much higher for the field data. This is commonly the case since eQUEST simulations assume that equipment is operating at its nameplate capacity and efficiency and that the facility is operated in a set manner. The baseline generated using the field data matching method captures the impact of equipment and occupant behavior that is not ideal. Additional work will need to be done as part of the Workpaper development process to establish the procedures for doing eQUEST simulations but it is clear that it is a reasonable approach.

	Baseline	Post-Retrofit	Savings	% Reduction
Measured (kWh)	17,400	5,000	12,400	71%
eQUEST (kWh)	14,100	2,600	11,500	82%

TABLE 2: SAVINGS SUMMARY FOR MEASURED AND eQUEST RESULTS

Figures 14 and 20 show how ERC1 technology functions to eliminate compressor run hours at outdoor temperatures below 75°F. At temperatures above 75°F compressor run time is on average cut in half. Thus it is not surprising that annual kWh savings are more than 50%.

The technology is not rated in tons or BTU/h as are typical RTUs, but in CFM. Based on 2330 CFM of delivered air and the average 22°F temperature differential between incoming air and supply air the unit as a sensible capacity (dry bulb temperature reduction) of:

$$\text{Sensible Capacity} = 1.08 \times 22 \times 2330 = 55,361 \text{ Btuh.}$$

To compare this sensible capacity with a standard RTU total capacity equivalence must be estimated. Based on manufacturer's data and normal operating conditions, the RTUs operate with a total capacity that is 75% sensible and 25% latent cooling. Thus this ERC1 is equivalent to an RTU with a total capacity of 73,814 (Total Capacity = Sensible/0.75) or about 6 tons given that dehumidification is not needed as is the case in Climate Zone 11. Thus the analyzed system was equivalent to a 6 ton dedicated outdoor air supply (DOAS) RTU system. With a power consumption of 1.8 kWh the efficiency achieved is in the range of 0.3 kW/ton compared to 1.2 kWh/ton for an RTU with Energy Efficiency Ratio (EER) of 10. The efficiency gain of 75% will translate into comparable energy savings measured in the field application.

The installation did not indicate maintenance problems. It was monitored for two weeks due to late installation compared to the cooling season. This system will be the focus of an intensive monitoring effort during the 2013 cooling season by the UC Davis Western Cooling Efficiency Center.

The evaluated ERC1 technology has an effective way to manage water consumption. The water line is connected to the unit which has a small tank. Water is re-circulated through the heat exchanger and then reused. The water tank has a conductivity sensor that activates a water replacement cycle when a certain concentration is achieved. It also has an electronic water treatment system to prevent algae growth. The water consumption is approximately 12 gal/hr for the 2,330 CFM unit. A California Energy Commission compliance option¹⁴ for an evaporatively-cooled split-system condenser set the maximum consumption at 5 gallon per hour per ton of capacity. For a standard 6-ton RTU this means 5 x 6 = 30 gallons per hour; ERC1 at 12 gallons per hour uses about 2/5 of this allowance.

RECOMMENDATIONS

ERC1 technology is ready for a wide range of commercial applications. The incentive amount for this technology should be increased from the current¹⁵ \$100/kW and \$0.15/kWh to offset the higher costs that are normal for an emerging technology. The benefits of this technology should be correctly modeled in CEC Title 24 simulation computer programs so that it can be included in the Savings By Design and New Construction programs so that the HVAC design community is encouraged to consider and deploy ERC1 technology,

The following criteria are recommended based on field observations and discussions with stakeholders:

- Each product type must be tested to deliver supply air at or below wet bulb temperature (100% evaporation effectiveness) before being included into an incentive program,

¹⁴ Compliance Option Evaporatively Cooled Condenser, p. 7.

¹⁵ 2012 Statewide Customized Offering Procedures Manual for Business, p.3. <http://www.aesc-inc.com/download/spc/2012SPCDocs/UnifiedManual/Customized%20Summary%20of%20Program%20Rules.pdf>

- A quality maintenance program must be provided that supports the unit for at least 3 years,
- An evaluation of the local water management regulations and statement of compliance must be provided,
- A commissioning test must be done for each installation that measures power consumption, outside air dry and wet bulb temperature, and supply dry and wet bulb temperature demonstrating that the system is working per manufacturer specification as part of the installation report,
- An operations manual must be provided that is specific to the site with modes of operation, control strategies, maintenance procedures, troubleshooting guidelines, and other information needed for a technician to keep the system operating correctly,
- A diagnostic component must be included to continuously verify the appropriate functioning of the system is initially encouraged and eventually required.

ERC2 – CONDENSER AIR PRE-COOLER

The principle behind ERC2 technologies is clearly shown in 21 from a series of lab tests on a unitary air conditioner.¹⁶ Outdoor air is cooled in a direct evaporative process by about 20 degrees shown by the superimposed dashed dark blue vertical line. At 95°F outdoor air temperature, power is reduced about 15%, capacity is increased by a few percent, and efficiency is raised over 20%. Condenser air intake for an RTU mounted on a hot roof can reach over 110°F on many summer days in California Climate Zones 10, 11, 12, 13, 14, and 15. An ERC2-type unit installed at a site with a 40 °F web bulb depression and an evaporative effectiveness of 0.6 delivers air at 86 °F as shown by the dotted purple line. Capacity is increased by over 10% and EER is increased by 30%.

Two similar but different technologies were tested at the sites. One technology collects the excess water in a sump and pumps it back to be sprayed on the evaporative media. The other sprays only the appropriate amount of water that can evaporate given the air conditions. The second type will be referred as "sump-less". The re-circulation technology has higher water consumption because water is sprayed continuously, but it also achieves higher evaporation effectiveness, perhaps due to more consistent wetting. Both technologies use a water treatment upstream of the spray nozzle(s) to avoid deposits and scaling. ERC2 type technologies have the lowest water consumption of the three technology types tested.

¹⁶ Davis, PG&E ATS, 491-08.6, Figure 3.

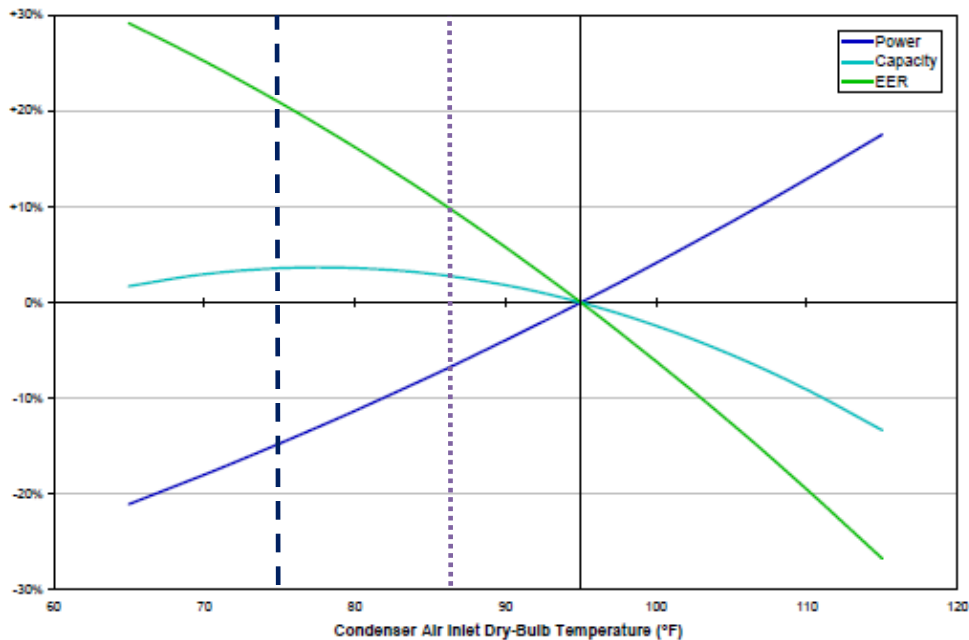

FIGURE 21— LAB TESTING SHOWING IMPACT OF OUTDOOR AIR ON RTU PERFORMANCE NORMALIZED TO 95°F RATING TEMPERATURE

DATA ANALYSIS

Sites #2, 3 and 4 installed ERC2-type system(s) on the existing air cooled air conditioning equipment as follows:

- Site #2 - two 50-ton air cooled RTUs,
- Site #3 - two-130 ton RTUs, one 75-ton RTU and one 10-ton condensing unit,
- Site #4 - one 35-ton RTU and one 50-ton RTU.

Data were collected and analyzed using the following procedure:

Current measurements were taken on all of the baseline units at one minute intervals and were averaged for an hour to calculate the kWh consumption, which was plotted in a scatter chart against the measured outside air dry bulb temperature (horizontal axis). All three sites are office-type buildings with normal office occupancy hours, and therefore all data outside normal business hours were removed from the data set. Following the system(s) retrofit, current measurements were again taken in one minute intervals, used to calculate the average kW draw for an hour by the units. The resulting kWh was plotted in a scatter chart against the outside air dry bulb. Regression lines for power vs. outside dry bulb were developed for each system both before and after system installation.

Figure 22 illustrates the data analysis findings at site #3. It should be noted that the other two sites did not perform well for various reasons and will be discussed further in the Evaluations section. For the pre-installation data, the linear regression showed an R^2 of 0.93. The post-installation regression of the total power showed an R^2 of 0.92. The two equations were then compared for the operating hours of the building for any temperature above 65°F.

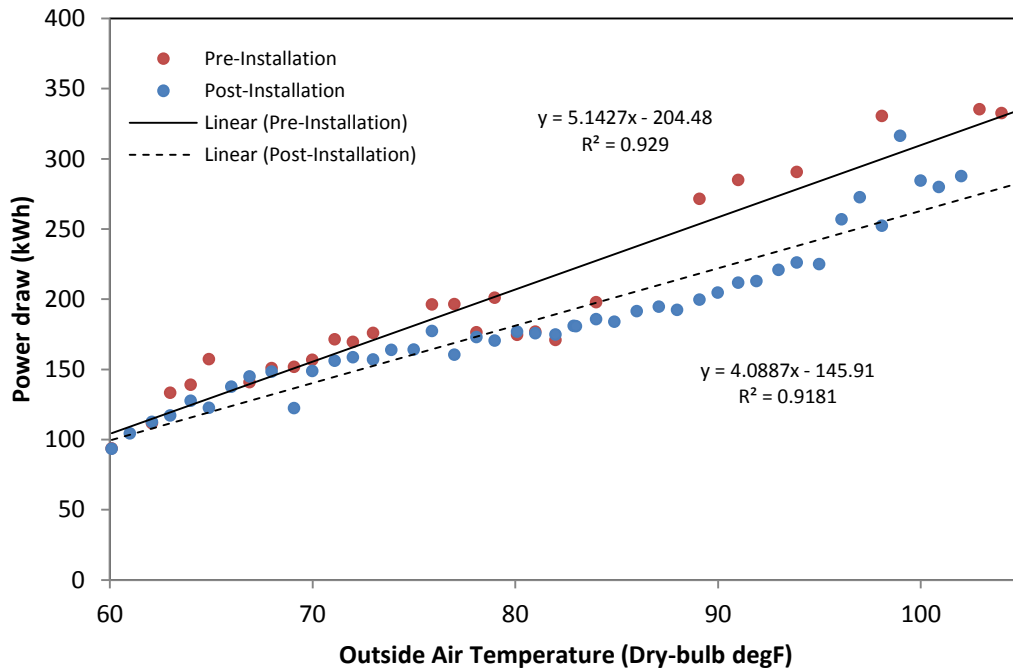

FIGURE 22 – ERC2 RETROFITTED RTU PRE AND POST INSTALLATION POWER VS. OUTSIDE AIR DRY BULB TEMPERATURE

To get a better understanding of the benefits of the installed ERC2 unit, a time versus kW comparison was done between two similar weather days (Figure 23). The results showed the ERC2 consistently reduced the overall HVAC electricity demand across a wide range of temperatures throughout the day. It is clear from the comparison that the ERC2 units installed at site #3 are effective in increasing the vapor compression cycle efficiency. Since this is actual data it displays the variability which commonly encountered in measure occupied buildings as shown by the cross-over of the pre and post kW lines in the afternoon of the particular days being plotted.

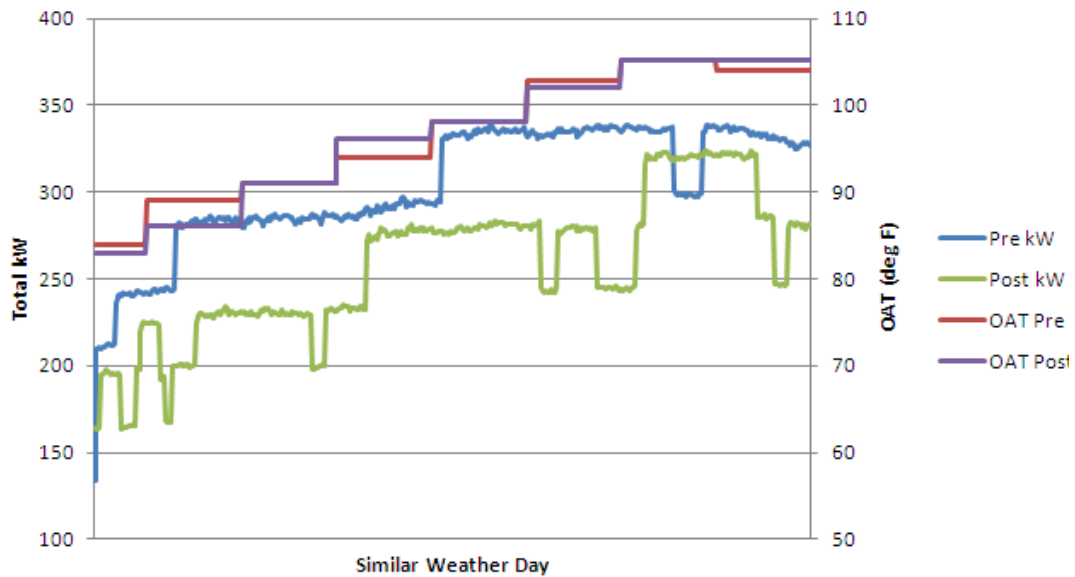

FIGURE 23 – TOTAL BUILDING HVAC POWER PRE AND POST-INSTALLATION COMPARISON BETWEEN TWO SIMILAR WEATHER DAYS

An additional analysis was performed to understand the relationships among temperatures, psychrometric processes, and kWh consumption. Figure 24 illustrates that the September ambient air dry bulb temperature (blue diamonds) is reduced as the ERC2 adds moisture to the air stream while the wet bulb temperature remains constant (black arrow starting at the average temperature going up and left to "1"). The process of the pre-cooled air traveling across the condenser coil is illustrated as the air is heated while the humidity ratio remains constant (black arrow going horizontally right to "2," the average temperature). The air temperature measurements illustrated in red triangles represent the condenser exhaust air temperature and is measured between the condensing coil and the condenser fans. The psychrometric chart allows us to analyze how effective the ERC2 is at reducing the ambient air temperature prior to entering the coil.

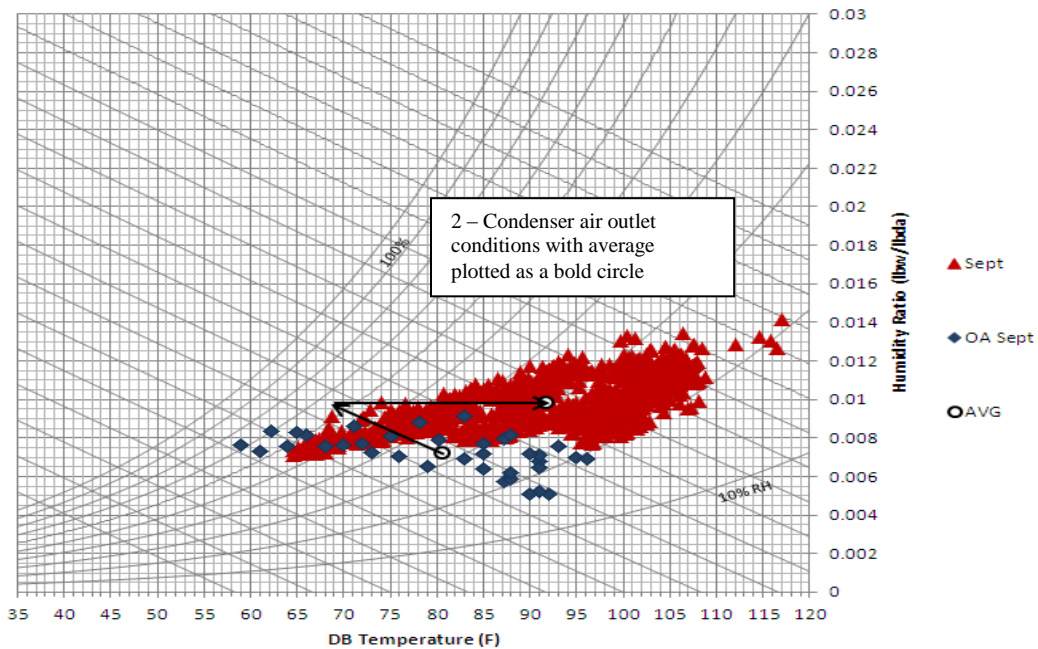

FIGURE 24 – PSYCHROMETRIC CHART SHOWING THE THERMODYNAMIC PATH OF THE ERC2 PROCESSES

If the evaporation effectiveness of this technology is compared to the wet bulb temperature the result averaged 66.7%. The evaporation effectiveness is calculated as the percent reduction from the dry bulb temperature to the wet bulb temperature. The calculated evaporation effectiveness is based on the average conditions during the operating hours of site #3 in September 2012.

$$Average\ Effectiveness = \left(\frac{T_{db,in} - T_{db,out}}{T_{db,in} - T_{wb,in}} \right) \times 100\%$$

$$Average\ Effectiveness = \left(\frac{81 - 69}{80 - 62} \right) \times 100\%$$

$$Average\ Effectiveness = \left(\frac{12}{18} \right) \times 100\% = 66.7\%$$

EVALUATION

Based on the results of annual hourly AESC spreadsheet simulation, the ERC2 technology is able to reduce the annual energy consumption by approximately 13% and peak demand by approximately 15%, if installed as a retrofit to an existing RTU. This result is in line with a study of the same technology by Sacramento Municipal Utility District¹⁷. Most of the energy savings came from the power reduction of the RTUs in the 65 to 85°F ambient temperature range, as a large percentage of the facilities’ operating hours occur within this range.

As part of future Workpaper development eQUEST simulation procedures will be developed. The program has the built in algorithms as shown below.

¹⁷ Mort and Bisbee, SMUD Report ET11SMUD1015, p. 1

EVAP-PRECOOLED The air-cooled condenser on a RESYS2, PSZ, PMZS, PVAVS, PTAC, PIU or PVVT system includes an evaporative precooler. The precooler is controlled by a time and/or temperature controller that decides if the unit should operate (see EVAP-PCC-SCH, EVAP-PCC-EFF, and EVAP-PCC-ELEC). When this unit doesn't operate, the condenser returns to CONDENSER-TYPE = AIR-COOLED. The evaporative precooler is only active during cooling mode. If no operation schedule is specified using EVAP-PCC-SCH, a default operation is assumed that provides for cooling mode operation whenever the outside dry-bulb temperature is more than 2F (1.1K) above the value of COOL-FT-MIN. 18

EVAP-PCC-EFF

The effectiveness of the evaporative process in an evaporative precooling unit. Equals the fraction of the maximum wet-bulb depression that can be realized by the outdoor air passing through the precooling unit before entering the condensing section. In any case, the approach to the wet-bulb temperature is not allowed to become smaller than 3F (1.7K) when the precooling unit is operating.

EVAP-PCC-ELEC

Gives the electric power consumption of the evaporative precooling unit divided by the cooling system output capacity at ARI conditions.

EVAP-PCC-SCH

Takes the U-name of a SCHEDULE that controls when the evaporatively precooled condenser for air cooled units can operate. A zero schedule value indicates that the unit is locked off. A value of 1 indicates the unit is operating. A value >1 indicates that the unit operates only if the outside temperature is less than the scheduled value. A value <0 indicates that the unit operates only if the outside temperature is greater than the absolute value of the schedule value (for example, for INPUT-UNITS = ENGLISH, a schedule value of -40 means that the unit operates only if the outside temperature is above 40F). 19

INSTRUCTIVE PERFORMANCE PROBLEMS

The ERC2 at site #3 performed almost as expected except for the 10-ton condensing unit (CRAC) serving the facility computer room. It is a horizontally-mounted condenser coil with air coming from underneath and exhausting up. No savings were shown and the media was found to be clogged with scale that blocked airflow and reduced evaporative effectiveness. Water treatment has been identified as the problem and the maintenance contractor is working with the manufacturer to solve the problems. Thus the criteria for ERC2 will include requirements for water treatment.

The ERC2s at sites #2 and #4 performed poorly and serve as clear examples of why installations must be designed, installed, and commissioned correctly.

Site #2 included the installation of ERC2 on two 50 ton RTUs. This site was monitored for one week pre-installation and for two months post-installation using the same practices and procedures as site #3. However, the results showed increased energy usage as shown by the current and temperature measurements. Visual inspections were made to make sure the system was operating. As described in the data analysis section above, the current measurements were used to calculate kWh consumption and were plotted against ambient air temperature in Figure 25. Condenser fan energy increased to overcome the resistance to airflow provided by the evaporative media but even more important is the increased energy use was due to the 3 horsepower pump used to circulate and spray water onto the media. At 80°F the pre installation kWh is 45 while the post installation kWh is 51.7 kW for a difference of 6.7 kWh.

¹⁸ DOE2.2 Library, p. 400. PSZ = Packaged Single Zone

¹⁹ DOE2.2 Library, p. 401

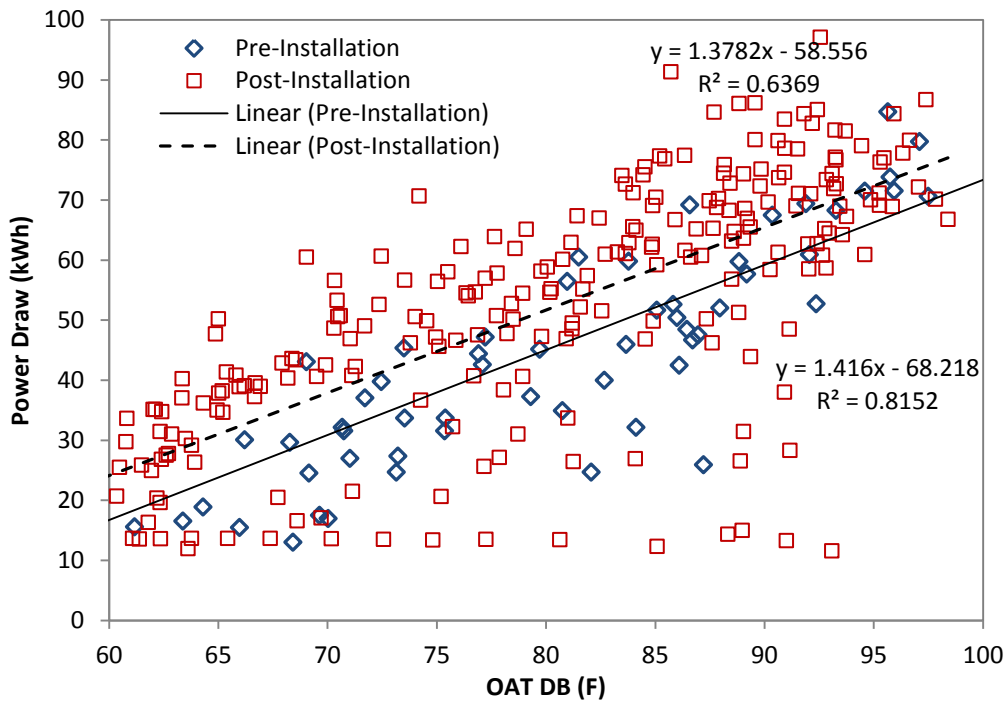

FIGURE 25 – LINEAR REGRESSION DEVELOPED FOR THE ERC2 INSTALLATION AT SITE #2

To confirm these findings the psychrometric chart was used to evaluate the efficiency of the pre-cooler. The chart made it clear that the ERC2 equipment at site #2 was not adding additional water to the condenser air stream (Figure 26). In other words, no pre-cooling took effect because no evaporation took place to reduce the temperature of the air.

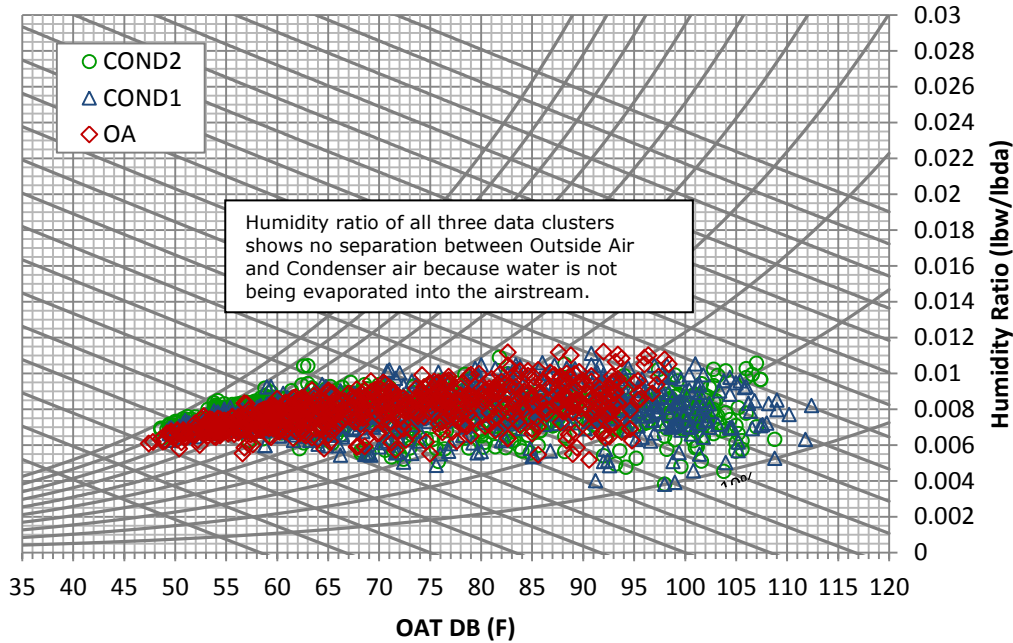

FIGURE 26 – ERC2 SITE #2 PSYCHROMETRIC CHART

Based on visual inspection and spot air flow measurements, it was determined that most of the air being pulled across the condenser at site #2 was not passing through the ERC2, but was rather entering the condenser from underneath thereby avoiding the resistance to flow from the evaporative media as shown in Figure 27. Modifications will be made prior to the 2013 cooling season to allow this ERC2 to operate correctly.

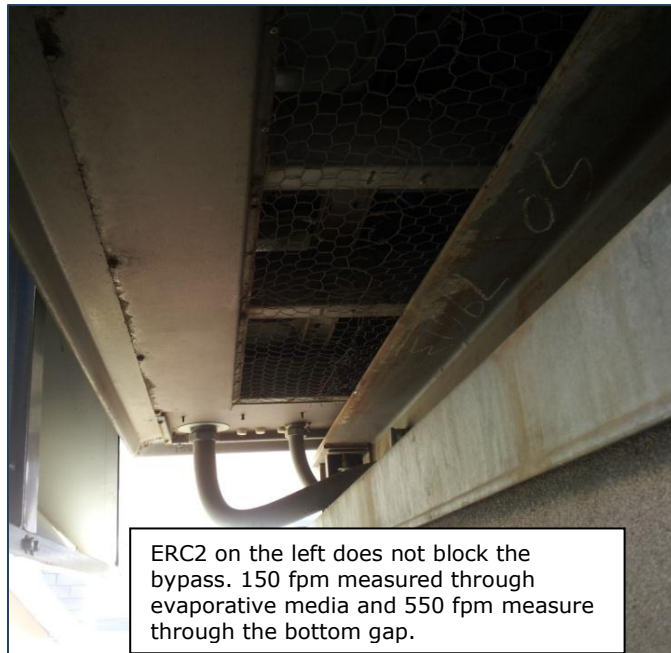

FIGURE 27 – ERC2 SITE #2 PHOTO OF BYPASS

The installation at site #4 failed due to insufficient water pressure to achieve proper spraying. City water pressure is both too low and too variable. To correct this problem, before the start of the 2013 cooling season a booster pump will be installed. Commissioning of the installation should have caught and corrected the problem unless the pressure was adequate at the time of installation. ERC2 technology that sprays water on a media must be installed so that constant and correct pressure is always available. If it is relying on city water pressure, it must be proven to be both adequate and consistent. The importance of performance monitoring is shown clearly in Figure 28. There is no change in the humidity ratio, showing no moisture gain.

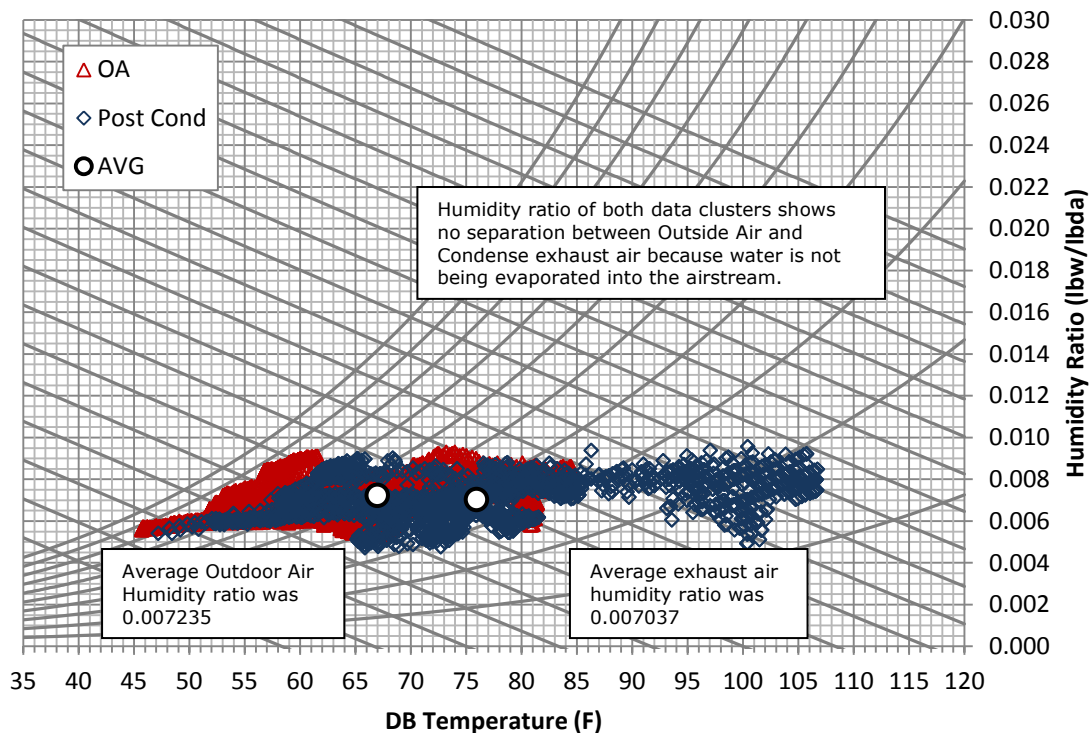

FIGURE 28- PSYCHROMETRICS OF SITE #3 SHOWING NO WATER ADDED

UC Davis Western Cooling Efficiency Center has initiated a project to develop a "Method of Test (MOT) for Determining Energy Performance and Water-Use Efficiency of Add-On Evaporative Pre-Coolers for Unitary Air Conditioning Equipment".²⁰ An ASHRAE standard process has begun in the Technical Committee 5.7. A progress report was made at the October 24, 2012 Stakeholders meeting which discussed the proposed methodology and initial results from testing three residential pre-cooler technologies. While the technologies did not work well the test method did work and clearly delineated system performance at four outdoor ambient dry and wet bulb conditions. The test outputs will be: evaporative effectiveness, power draw reduction, capacity increase, water consumption, effective water

²⁰ UC Davis Western Cooling Efficiency Center; 3rd Quarter 2012 News Letter, p. 9 <http://wcec.ucdavis.edu/resources/newsletter/>

evaporation fraction, and performance degradation due to water consumption. It is recommended that systems be tested using the WCEC test to demonstrate that they meet energy efficiency program criteria.

ERC2 installations can provide non-energy benefits. The evaporative media in front of the coil prevents most of the typical contamination and clogging, thus reducing the maintenance cost of the coils, although they increase the maintenance cost of the evaporative media. Protecting the condenser coils can result in increased equipment life expectancy. In addition, the added capacity of the ERC2 type system to the existing equipment can avoid the need for installing new or additional RTU to serve an increased load.

RECOMMENDATIONS

ERC2 technologies, both those tested and those that use rigid media with a sump and pump, are ready for a wide range of commercial applications. However, given the issues discovered in the study, it is suggested that future installations are monitored to verify appropriate operation.

The following criteria are recommended based on field observations and discussions with stakeholders:

- Each product must be tested using the WCEC MOT to meet the minimum 60% evaporation effectiveness,
- A quality maintenance program must be provided that supports the unit for at least 3 years,
- An evaluation of the local water management regulations and statement of compliance must be provided,
- A commissioning test must be done for each installation that measures power consumption, outside air dry and wet bulb temperature, and after condenser coil dry and wet bulb temperature demonstrating that the system is working per manufacturer specification as part of the installation report,
- An operations manual must be provided that is specific to the site, including modes of operation, control strategies, maintenance procedures, troubleshooting guidelines, and other information needed for a technician to keep the system operating correctly,
- A diagnostic component is required to continuously verify the appropriate functioning of the system is initially encouraged and eventually required.

ERC3 – INTEGRATED COMBINATION

DATA ANALYSIS

At sites #5 and 6, ERC3 technology was added to the existing two-stage RTUs with air-cooled condensers serving the large retail sales spaces which make up over 80% of the facility's floor space. Current measurements were taken on all units at both sites using one-to six-minute intervals and were used to calculate the kWh consumption. Pre-installation measurements were taken during the month of May and post-installation measurements were taken over a four month period (June to September). The collected pre-and post-installation data were averaged hourly and compared in a scatter chart of power draw

versus measured outside air dry bulb temperature. Both stores operate 24 hours a day with one being open for customers 12 hours a day with stocking being done while the store is closed. The results plotted in Figure 29 show decreased kW demand overall as well as per-unit basis. The savings are more evident at higher temperatures because the increased capacity from the direct evaporative cooling on the condenser side and the indirect evaporative cooling of OAS on the supply side allowed the DX unit to cool using a lower stage compressor even at higher temperatures. The pre-installation data was done prior to the period when 100°F temperatures began occurring. The regression equation can be used to predict a kW of 256 kW this compares to a predicted 234 kW for the post installation demand which is an 8.5% reduction for all of the RTUs even though only 6 of 38 RTUs were retrofitted.

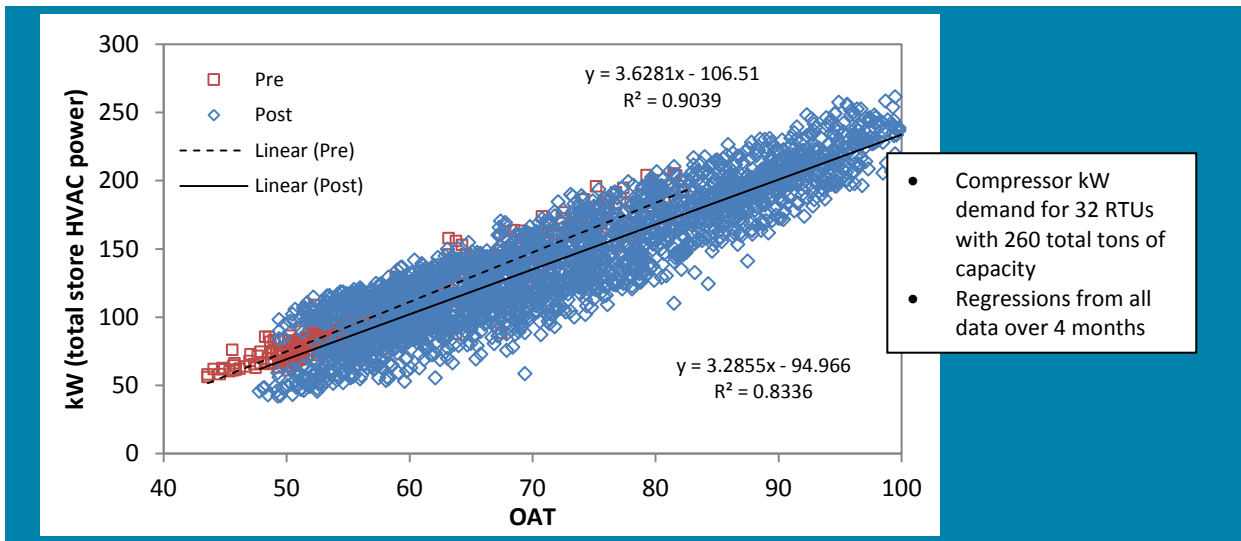

FIGURE 29 - TOTAL kW DEMAND OF RTUs MEASURED PRE- AND POST-INSTALLATION OF THE ERC3 TECHNOLOGY SITE #6

In Figure 30 the purple diamonds show performance prior to ERC3 installation of one RTU. The ambient outdoor temperatures are lower during the May test period that occur later but still the RTU uses about 10 kW when outdoor temperatures are in the mid-60s to 80°F. The green triangles show that consumption does not get to 10 kW until 89 °F. Also, the cluster of data points around 6 kW shows that the first stage cooling is handling the load with only the ERC3. At 80°F, shown by the vertical dark blue dotted line, the 10 kW usage by the RTU drops to 6.9 kW in the worst case for a 31% savings. Also note that there are many temperatures where the post installation RTU used no compressor cooling as it met the load with only the ERC3 operating as an extended range economizer.

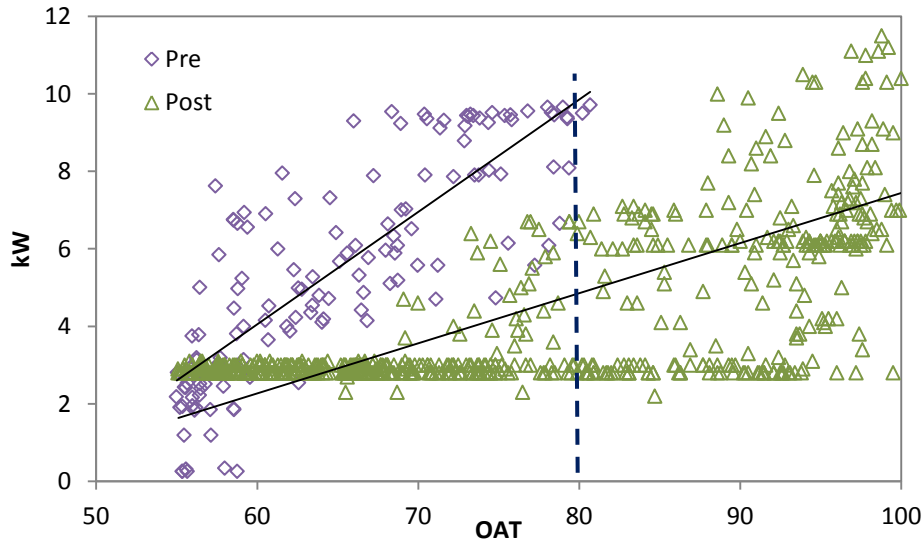

FIGURE 30 – ENERGY DEMAND OF AN ERC3 RETROFITTED RTU

The evaporative cooling effectiveness achieved by the ERC3 technology was derived by comparing the psychrometric state of the outside air and the exhaust condenser air and the OAS temperature. Dry bulb temperature and relative humidity data collected was used to calculate the humidity ratio, which was plotted in the Figure 31 psychrometric chart. The field test results showed an increase in humidity ratio at all points indicating that the evaporative cooling was performed effectively. The thermodynamic path of the air (indicated by arrows on the chart) was used to calculate the evaporative cooling efficiency. On average, the ERC3 technology condenser air pre-cooler was able to achieve a direct evaporative cooling efficiency of 79% but testing to the WCEC method of test is needed to establish the value for a particular product. In this version of ERC3 the pre-cooler uses rigid media with sump and pump. It is logical that a similar evaporative efficiency would be achieved when used as an ERC2.

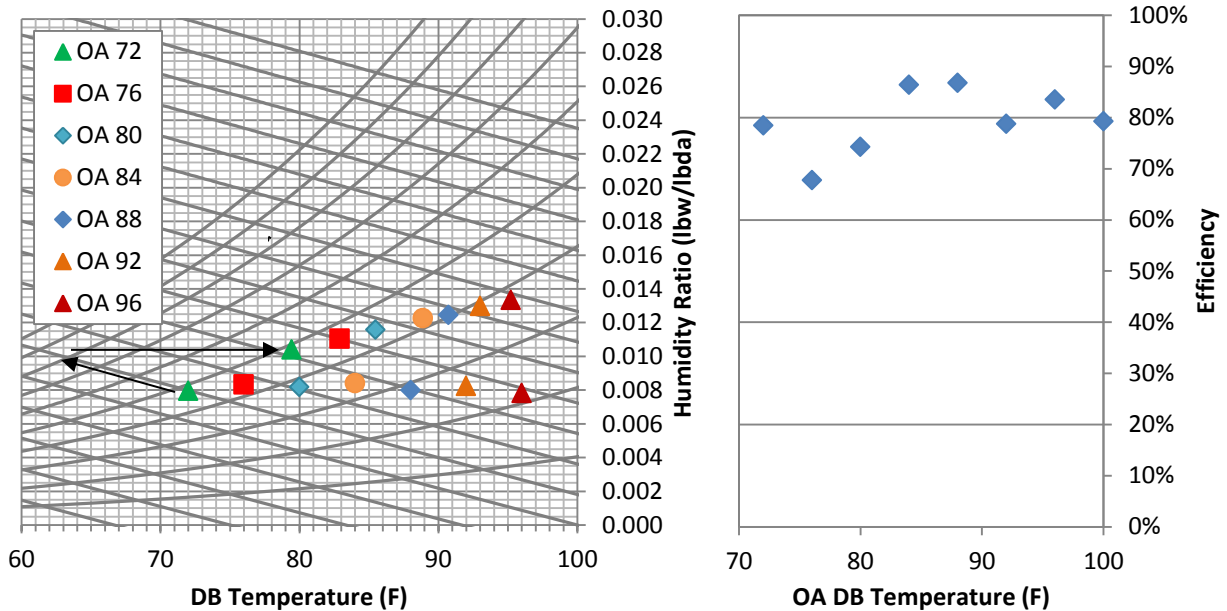

FIGURE 31 – PSYCHROMETRIC STATES AND EVAPORATIVE COOLING EFFECTIVENESS OF CONDENSER AIR WITH RESPECT TO OUTSIDE AIR TEMPERATURE.

The effectiveness of indirect evaporative cooling is a function of the heat exchanger and the water temperature compared to the wet bulb temperature. As shown below, the supply air temperature data showed significant cooling effect throughout the day, especially during peak hours. Figure 32 is a plot of a representative day for three RTUs. The outlet temperatures of the OAS sections of the ERC3 installations show the beneficial impact of the technology. The average evaporative effectiveness of the OAS pre-cooler is calculated as 40%.

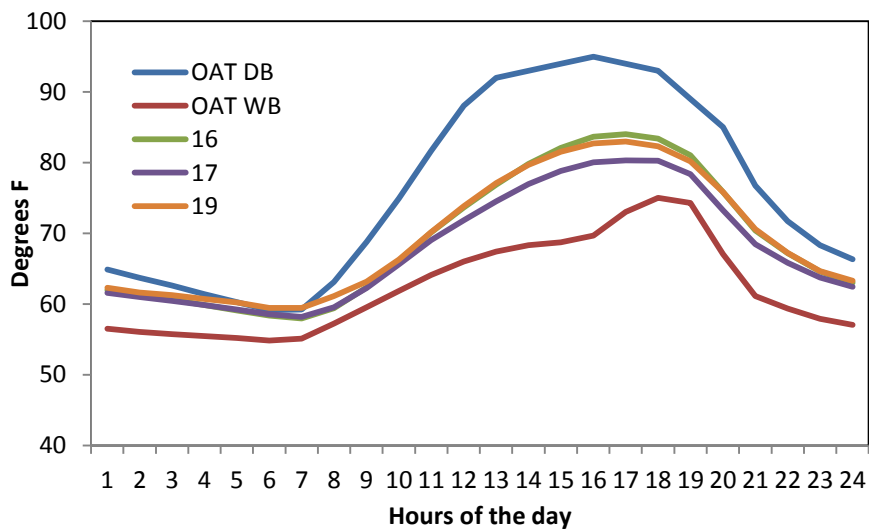

FIGURE 32 - SUPPLY AIR TEMPERATURES OF THE RETROFITTED UNITS (#16, 17, AND 19)

The evaporative effectiveness with respect to wet bulb temperature was calculated using Equation 1. To understand the effectiveness of the water to air coil that is cooling the entering OAS the sump water temperature is used in the equation below. In this instance, the incoming dry bulb temperature refers to the outside air dry bulb temperature and outgoing dry bulb temperature refers to pre-cooled supply air temperature (before it mixes with the return air).

$$Effectiveness = \left(\frac{T_{db,in} - T_{db,out}}{T_{db,in} - T_{sump,in}} \right) \times 100\%$$

The measured effectiveness of indirect evaporative cooling averaged for all of the RTUs 50% when compared to the sump water temperature and 40% when compared to wet bulb temperature of the outside air. As an example, one RTU had the following average performance:

Averages for one RTU for the period of testing					
Outdoor Dry Bulb Temperature	Outdoor Wet Bulb Temperature	Outlet Dry Bulb Temperature of Pre-cooled OAS	ERC3 Sump Water Temperature	Evaporative Effectiveness - Wet Bulb	Evaporative Effectiveness - Sump Water
79.2°F	60.4°F	71.5°F	64.2°F	41%	52%

TABLE 3: AVERAGE INDIRECT SECTION EVAPORATIVE EFFECTIVENESS

The wet bulb evaporative effectiveness of indirect evaporative cooling is a function of the heat exchanger and the water temperature compared to the wet bulb temperature and is 41%. When compared to the sump water temperature the evaporative effectiveness is 52%. Sump water temperature is warmer than wet bulb temperature of outside air since the direct evaporative process does not reach 100% evaporative effectiveness.

EVALUATIONS

Based on the above results and calculation tool developed by AESC, the annual demand and energy savings of the ERC3 technology were evaluated. The calculation tool is able to estimate the savings associated with direct and indirect evaporative cooling technologies utilizing the measured load, weather data, and equipment information. Using the AESC spreadsheet annual estimation results, the addition of ERC3 technology to an existing RTU can reduce the energy consumption as much as 15% and 35% reduction in peak demand. Workpaper eQUEST analysis in all 16 California Climate Zones for a set of building prototypes will show the energy impacts of ERC3.

ERC3 technology increases the capacity of the RTU by increasing the efficiency of the refrigeration cycle and by lowering the cooling capacity needed to cool outside air. As a result, most of the energy savings come from reduced usage of the second compressor. The 70 to 85°F range constitutes a large percentage of the facility's operating hours, and most of the power reduction of the RTUs, occurs within this range. ERC3 is also a means of increasing cooling capacity without having to purchase/install additional RTUs.

Control strategies for the ERC3 sites were shown to need adjustment. Figure 33 shows the total power consumption of RTUs at site #5 for the months of May (pre-installation period) and June (post-installation period). The results show that the total power consumption decreased at higher temperatures, but was slightly higher at the lower temperatures. Site #6 showed similar trends.

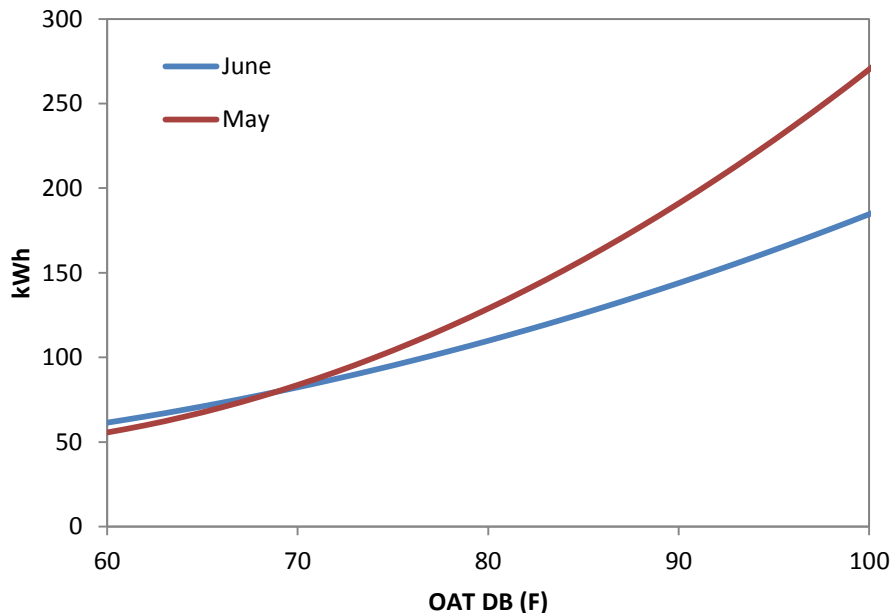

FIGURE 33 - REGRESSED PRE- AND POST-INSTALLATION TOTAL ENERGY USAGE OF RTUS SITE #5

Several factors were investigated for the increased power consumption at lower temperatures:

1. The evaporative cooling effectiveness of the installed technology at low temperatures was a potential factor, but psychrometric data showed that the effectiveness does not change (Figure 24). The effectiveness was derived from comparing the psychrometric state of the outside air entering the condenser and the air leaving the condenser from the temperature and relative humidity data collected. However, as Figure shows, the increase in humidity ratio and decrease in various outside air temperatures establishes that evaporative cooling was effectively performed, which was confirmed by the calculated evaporative cooling effectiveness of approximately 80%.
2. Another reason investigated for the consumption was the benefit of the pre-cooled air at low temperatures compared to the added power due to the pump. It should be noted that the pump uses 220 Watt and that at 65°F the system protects the high pressure side by not allowing the condensing temperature to decrease any further. Therefore, the increase in power due to the added pump is not offset improved operation of the compressor.
3. Finally, the OAS airflow reduction due to the indirect cooling heat exchanger coil pressure drop reduces the amount of air that the unit can bring in while in economizing mode. Therefore, even if the unit is in economizing mode, there is less airflow to satisfy the cooling load of the zone and at times the compressor might still come on. This is a problem encountered in many single-speed HVAC systems that

have variable load and it is believed that the small flow reduction could also have an impact.

The solution is to raise the temperature at which the ERC3 starts to operate to 70°F where the pre- and post- lines cross (Figure 34). This also solves another problem. A visual inspection of the ERC3 units showed algae growth due to the long operating hours of the evaporative media (initially the system was set to come on at 60°F). The set point was adjusted accordingly later in the season and the algae was gone within a few weeks. Since the 10 degrees between 60 and 70°F have a lot of bin hours in the climate zone tested, the increase in the set point significantly reduced the energy consumed by the pumps.



FIGURE 34 – ALGAE GROWTH AND CALCIUM BUILD-UP WAS OBSERVED ON THE DIRECT EVAPORATIVE COOLING MEDIA

Sequence of operation was also found to be an important factor for the overall store power consumption. The ERC3 technology was added to 6 of 38 existing RTUs at site #5 and 10 of 32 existing RTUs at site #6. All of the units serve one large retail space. In concept the retrofitted RTUs are staged to be the OAS units providing the required ventilation and the first stages of heating and cooling. The other RTUs become heating- and cooling-only units that turn on only when cooling is not being met by the retrofitted RTUs. The post-installation data showed that the retrofitted units were running no more than the non-retrofitted ones. However, because of the interactions of the units in a big box type store, it was suggested that the retrofitted units have a lower cooling set point to provide more cooling to the store compared to the non-retrofitted units, thereby maximizing the benefits of the ERC3 technology. Controls were modified to have the cooling thermostat set point on the retrofitted RTUs set 3°F below the set point of the non-retrofitted units. The store showed increased savings confirming that the sequence of operations is a significant factor in maximizing the savings of the ERC3 retrofit and is the rationale for having commissioning and control strategies clearly defined for each installation.

The ERC3 units have a constant rate of water discharge that is set up during the installation based on the hardness of the water. This is standard practice for many evaporative cooling technologies. Research at WCEC into better non-chemical control strategies shows promise for achieving better water quality with less discharge.²¹

²¹ <http://wcec.ucdavis.edu/research/by-technology-topic/water-management-for-evaporative-systems/>

RECOMMENDATIONS

The tested ERC3 technology is ready for a wide range of commercial applications. However, a few more installations should be monitored to confirm the savings reported in this study. The incentive amount for this technology should be increased from the current \$100/kW and \$0.15/kWh due to high initial capital expenditure. The benefit of this technology should be included as soon as possible in the Savings By Design and New Construction programs so that the HVAC design community has an incentive in deploying this technology,

The following criteria are recommended based on field observations and discussions with stakeholders:

- Each product must be tested using the WCEC MOT for the evaporative pre-cooler section to meet the minimum 60% evaporation effectiveness and 60% effectiveness of the OAS pre-cooler before being included into an incentive program,
- A quality maintenance program must be provided that supports the unit for at least 3 years,
- An evaluation of the local water management regulations and statement of compliance is required,
- A commissioning test must be done for each installation that measures power consumption, outside air dry and wet bulb temperature, after condenser coil dry and wet bulb temperature, and the temperature of the OSA pre-cooler demonstrating that the system is working per manufacturer specification as part of the installation report,
- An operations manual must be provided that is specific to the site with modes of operation, control strategies, maintenance procedures, troubleshooting guidelines, and other information needed for a technician to keep the system operating correctly,
- A diagnostic component to continuously verify the appropriate functioning of the system is initially encouraged and eventually required.
- The ERC3 pump set point should be at a minimum of 70°F so that the benefits of lower condensing temperature are captured without incurring too much pump penalty, algae growth, and water consumption.
- Additional water treatment is required to avoid calcium build-up and to limit the water wasted in blow down; or alternatively sensors must be introduced to measure conductivity and blow down the water accordingly.
- Control sequence should be organized carefully. Because of the flow resistance on the condenser side due to the evaporative media, the ERC3 retrofitted units are less efficient in providing cooling when outside air temperature is below 70°F. Therefore, in the EMS logic of multiunit installation, it is recommended that non-retrofitted units are the lead units when outside temperature is below 70°F and the ERC3 retrofitted units are the lead and non-retrofitted units are lag units at temperatures above 70°F. The recommendation is only for sites with multiple units, some with and some without the ERC3 retrofit.
- The adaptation of the variable frequency drive on supply and condenser fans may be considered for additional savings.

REFERENCES

1. ANSI/ASHRAE/ACCA Standard 180-2012, *Standard Practice for Inspection and Maintenance of Commercial Building HVAC Systems*, ACCA/ASHRAE 2012. <https://www.acca.org/store/product.php?pid=317>
2. Davis, Robert, *Evaluation of Advanced Evaporative Cooler Technologies*, PG&E Technical and Ecological Services (now Applied Technology Services – ATS), Report #491-04.7, February 2004. http://www.etcc-ca.com/images/stories/pdf/ETCC_Report_208.pdf
3. Davis, Robert, *Evaluation of a Thick Media Evaporative Cooler*, PG&E Technical and Ecological Services (now Applied Technology Services – ATS), Report #491-04.31, November 2004. http://www.etcc-ca.com/images/stories/pdf/ETCC_Report_303.pdf
4. Davis, Robert, *Laboratory Evaluation of the Coolerado Cooler Indirect Evaporative Cooling Unit*, PG&E Technical and Ecological Services (now Applied Technology Services – ATS), Report #491-05.6, March 2005. http://www.etcc-ca.com/images/stories/pdf/ETCC_Report_304.pdf
5. Davis, Robert. *Laboratory Evaluation of the Coolerado Cooler Indirect Evaporative Cooling Unit*: PG&E Technical and Ecological Services (now Applied Technology Services – ATS), Report #491-05.6, March 2006.
6. Davis, Robert, *Laboratory Evaluation of the OASys Indirect/Direct Evaporative Cooling Unit*, PG&E Technical and Ecological Services (now Applied Technology Services – ATS), Report #491-06.12, November 2006. http://www.etcc-ca.com/images/stories/pdf/ETCC_Report_365.pdf
7. Davis, Robert. *Evaluation of the Viridis Earth™ Condenser Air Evaporative Pre-cooler*, Memorandum File 491-08.6, November 2008.
8. Davis, Robert, *Laboratory Evaluation of the Seeley Climate Wizard Indirect Evaporative Cooler*, PG&E Applied Technology Services – ATS, Report #491-09.12, September 2009. <http://www.etcc-ca.com/images/etaar0911-climatewizardeval.pdf>
9. E. O. Lawrence Berkeley National Laboratory, Simulation Research Group (LBNL) and James J. Hirsch & Associates (Hirsch), *DOE-2.2 Building Energy Use and Cost Analysis Program Volume 2: Dictionary*, December 2009 <http://doe2.com/equest/index.html>
10. Efficiency Valuation Organization, *International Performance Measurement and Verification Protocol: Concepts and Options for Determining Energy and Water Savings, Volume 1*, EVO 10000-1:2009, September 2009. http://www.evo-world.org/index.php?option=com_content&view=article&id=272&Itemid=504&lang=en
11. Mort, Daniel (ADM Inc.) and Dave Bisbee (SMUD), *Evaporcool Precooling System*, Sacramento Municipal Utility District, February 2010. [http://www.etcc-ca.com/images/ET09SMUD1011%20\(Evaporcool\).pdf](http://www.etcc-ca.com/images/ET09SMUD1011%20(Evaporcool).pdf)